

# 4600 RIM DEVICE WITH 2945 DOOR PREP TEMPLATE

APPLICATION FOR METAL AND WOOD DOORS  
(FOR PANIC AND FIRE RATED DEVICES)

## NOTES:

1. LHR door shown. Preparation is typical for both door hands.
2. Please see 4600 Series Rim Exit Device Installation Instructions (I-ED01162 and T-ED01192) for sizing.
3. Exit device must be installed first before 2945 strike.
4. Provide door stiffeners as needed to prevent door collapse due to installation with power tools, door use, or abuse.
5. This is a nominal dimension and is measured to the door face. mount the Exit device then mount the strike to proper centerline. Ensure the dead latch is in the proper position and does not fall into the strike.
6. These holes are pilot holes. Thread with 1/4"-20 tap.
7. Wire hole position will change in relation to the strike center line based on device handing.
8. These are Pilot holes for spacer mounting Hardware.
9. Spacer Center Line matches Strike Center line.

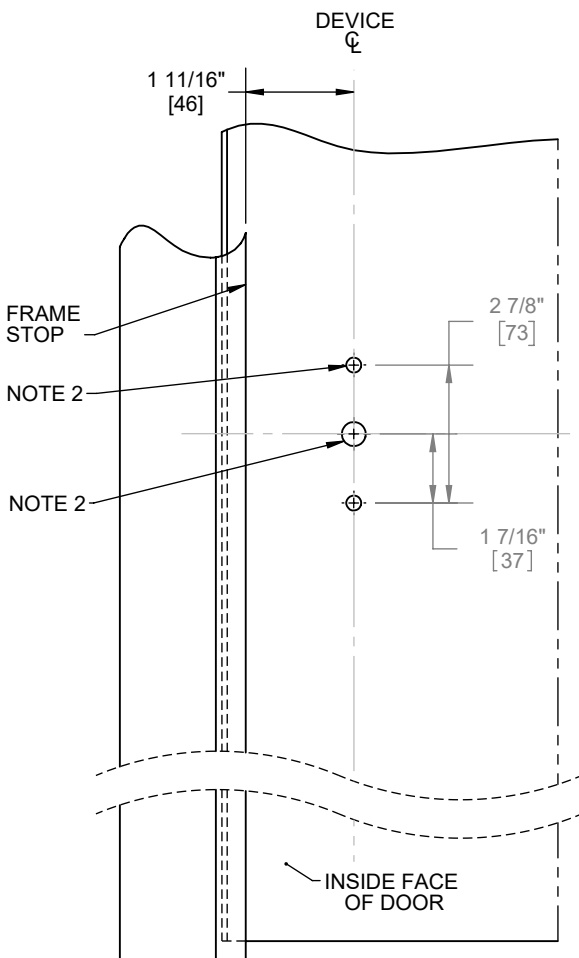
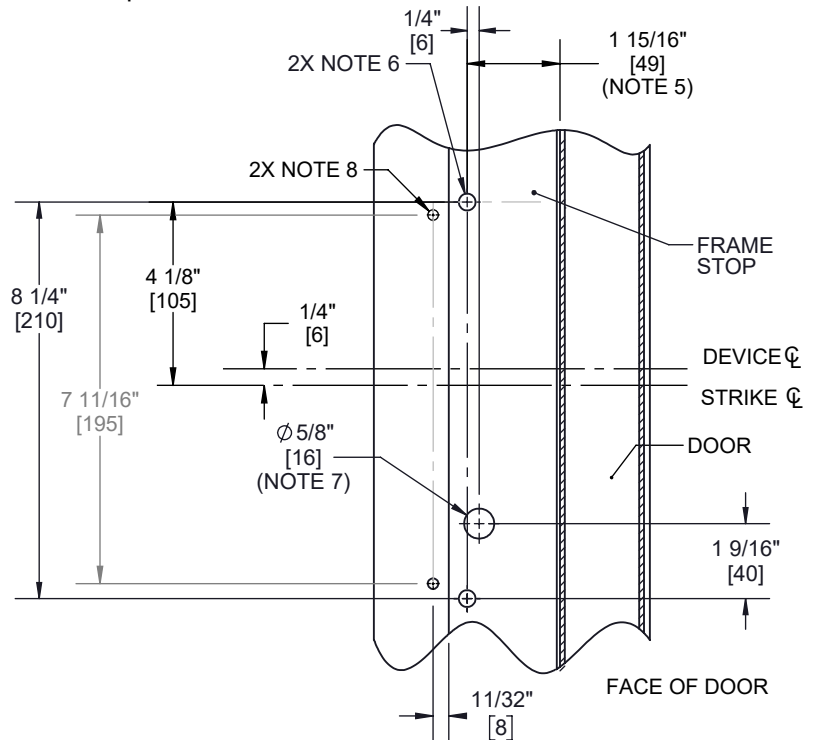
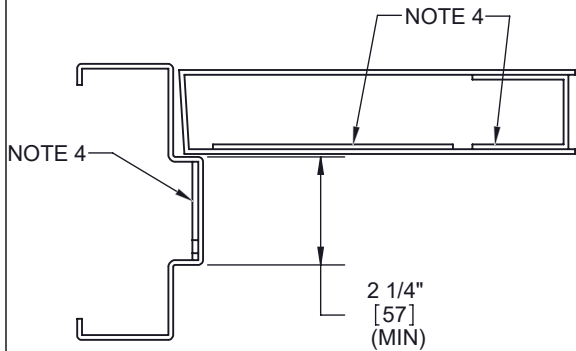

## STRIKE PREPARATION DETAIL

