

MAGNALOCK®
**M380BDC/M380BDC2/M380BDX/
M380BDCX/M380BDC2X**
Installation Instructions



Table of Contents

Warranty.....	3
Package Contents	4
Mounting Hardware	4
Recommended Tools	5
Specifications	5
Magnalock Preparation and Installation	6
Performing a Pre-Installation Survey.....	6
Positioning the Camera and PIR REX Module Locations in the Magnalock.....	6
Preparing the Magnalock	9
Locating and Setting the Components	10
Documenting the Configuration Settings.....	15
Installing the Magnalock.....	17
Installing the Strike.....	21
Assembling the Lock to the Bracket and Adjusting, as Necessary.....	25
Performing Final Installation.....	27
Performing the Final Wiring.....	28
Magnalock Operation With Access Control System	32
Magnalock Operation With Local Control	33
Magnalock Maintenance.....	33
Proper Cleaning Methods.....	33
Troubleshooting Guide	34
LED Error Codes	35



YouTube Channel: SecuritronAccess
Watch the overall installation
<http://tinyurl.com/M380video>

Warranty

The MAGNALOCK® series of locks are covered by the MagnaCare® lifetime replacement no fault warranty. No registration is required. Product will be replaced forever, for any reason, including but not limited to installation error, vandalism, or act of God. Replacement product is shipped at Securitron's expense next day air if needed.

For more information, visit www.securitron.com

Package Contents

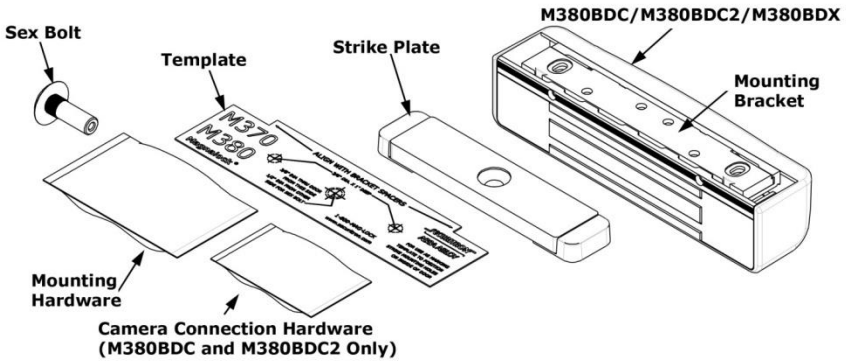

Mounting Hardware

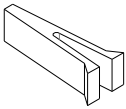

(2) x Bracket
Spacer

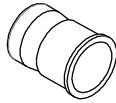

(2) x 1/4-20
Blind Nut

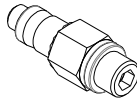

(1) x – Blind Nut
Installation Tool

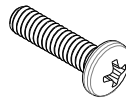

(2) x 1/4-20 x 1"
Phillips Pan Head

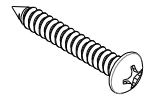

(4) x #12 x 1-1/2"
Type A Phillips Pan
Head

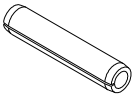

(2) x 1/4" x 1-1/4"
Roll Pin

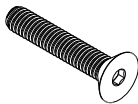

(1) x 5/16-18 x 1-
3/4" Flat Head
Socket

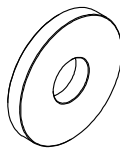

(3) x – Neoprene
Washer

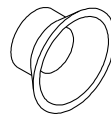

(1) x Plastic Strike
Bushing



(4) x #14 x 3"
Type A Phillips
Pan Head

Recommended Tools

Masking Tape	#1 and #2 Phillips Screwdrivers	Hammer
Measuring Device	1/2" Open End or Crescent Wrench	Pencil/Pen
Center Punch	Wire Strippers/Cutter	Multimeter
Fish Tape or Lead Wire	3/16" Hex (Allen) Wrench	
Drill bits: 3/16", 7/32" (wood frames only), 3/8", 1/2"		

Specifications

Mechanical

Physical Size:

Height: 2.20" [56mm]

Depth: 2.45" [62mm]

Length: 10.00" [254mm]

Shipped Weight:

Weight: 6.5 lb

Holding Force (Maximum):

600 lbs [272 kg]

UL Tested Ratings:

Static Holding Force:
500 lbs [227 kg]

Dynamic Holding Force:
50 ft-lbs [68 J]

Endurance: 250,000
cycles

Electrical

Input Voltage:

12/24 VDC. Power must be at least Rectified and Filtered to meet minimum electrical specifications. AC, Half Wave, and Full Wave power is unacceptable.

Magnalock Current

12 VDC/550 mA
(±10%)

24 VDC/300 mA
(±10%)

Optional Camera Current

12 VDC/200 mA
(±10%)

24 VDC/80 mA (±10%)

Optional Passive Infrared (PIR) Current

12 VDC/25 mA (±10%)

24 VDC/10 mA (±10%)

Environmental (Recommended)

Operating Temperature

32°F to 110°F [0°C to 43°C]

Humidity

10% to 90% RH

Camera Specifications

Color Version:

Horizontal Resolution: 520 TV
Lines

Video Output: 1 V_{P-P}, 75Ω

Minimum Illumination: 1.5 LUX

Black and White Version:

Horizontal Resolution: 420 TV
Lines

Video Output: 1 V_{P-P}, 75Ω

Minimum Illumination: 0.1 LUX

Magnalock Preparation and Installation

Performing a Pre-Installation Survey

1. Before installing the Magnalock, DETERMINE and ASSESS the mounting location for the following:
 - Physical strength of the frame— it should be strong enough to meet or exceed the holding force of the Magnalock.
 - Frame and vicinity— it should offer protection for the wiring to prevent vandalism.
 - Door inspection—it should be inspected for any obstacles that may interfere when mounting the strike plate.
 - Proper mounting—The Magnalock M380 comes with factory default mounting for use with an outswing door. Securitron should be contacted for available brackets for other installation configurations.

Positioning the Camera and PIR REX Module Locations in the Magnalock

NOTE 1: The physical position of the camera or PIR REX Module may be reconfigured for either end of the Magnalock, as desired.

NOTE 2: If the Magnalock is equipped with both camera and PIR, each module position may be reversed from the factory default positions (see Figure 1, “Camera and PIR Reversing.”)

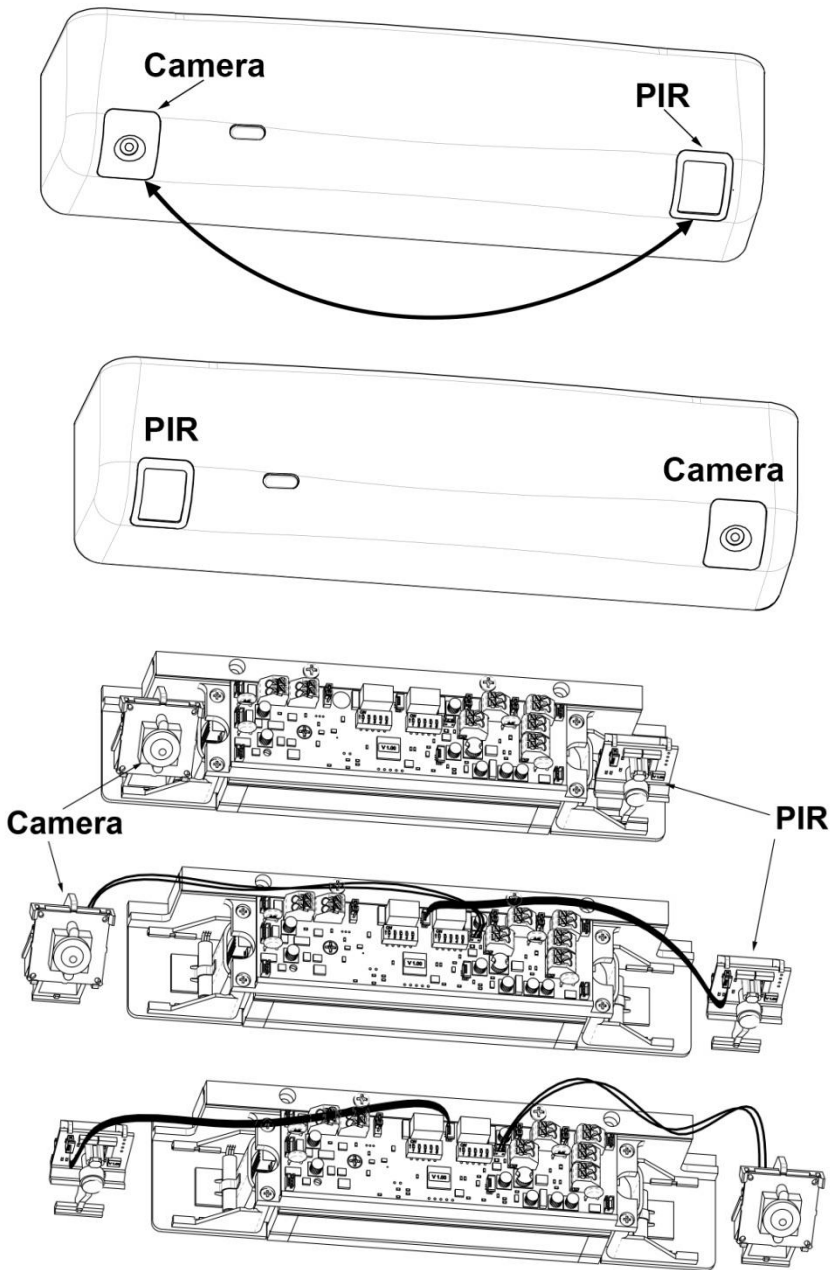

Figure 1. Camera and PIR Reversing

1. To remove or install a module, COMPRESS the legs of the support bracket and SLIDE the module bracket in or out of the retaining rails (see Figure 2, “Removing and Installing a Module”).

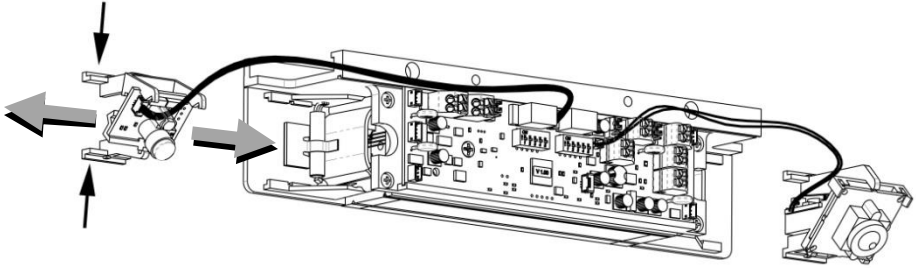

Figure 2. Removing and Installing a Module

2. REMOVE, REPOSITION, and REINSTALL the module inserts in the cover, as necessary, using a #1 Phillips screwdriver (see Figure 3, “Removing, Repositioning, and Reinstalling the Module Inserts.”)

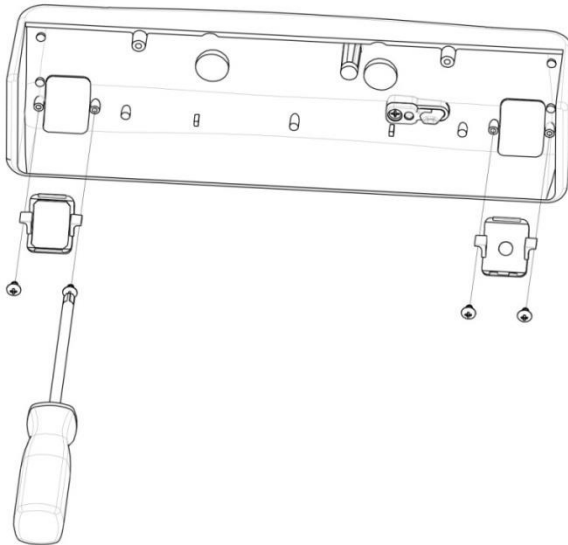

Figure 3. Removing, Repositioning, and Reinstalling the Module Inserts

Preparing the Magnalock

NOTE: Removing the cover provides access to the circuit board and on the back of the magnet.

1. Using a Phillips screwdriver, REMOVE the two (2) screws securing the cover, as shown in Figure 4, "Removing the Cover Screws."
2. SET the screws aside to re-attach the cover later.

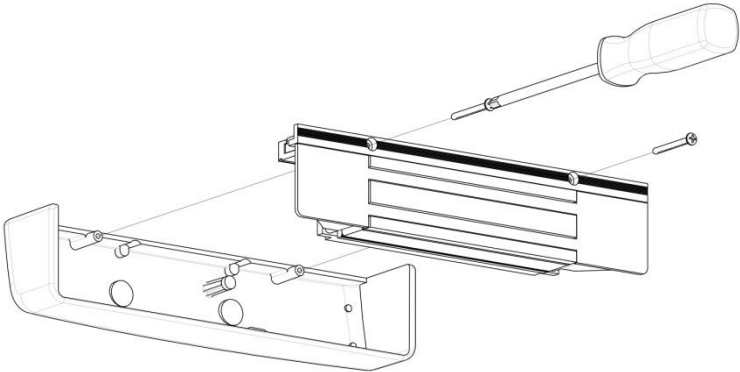

Figure 4. Removing the Cover Screws

Locating and Setting the Components

1. LOCATE and SET the components in the M380 using Figure 5, "Component Locations," and Table 1, "Component Label, Name, Selection, and Position."

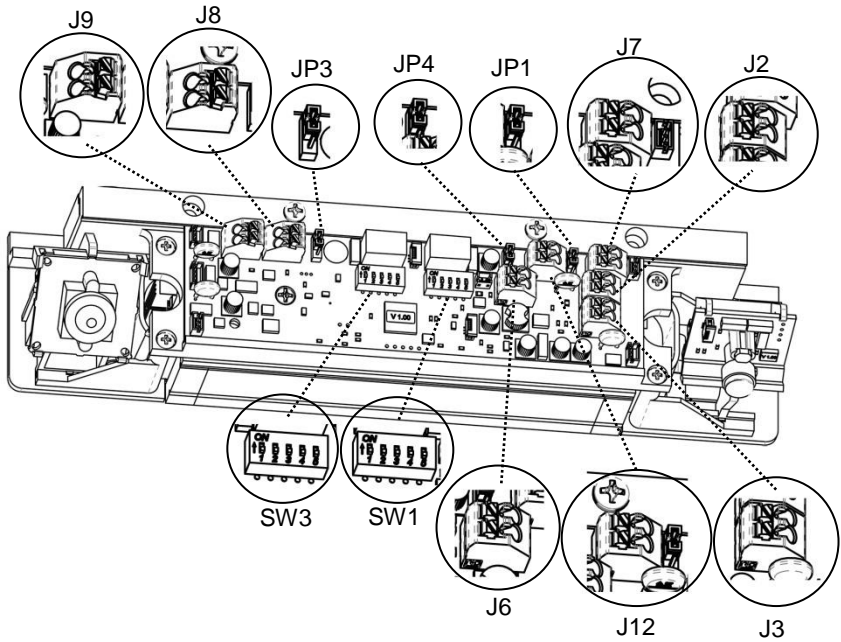
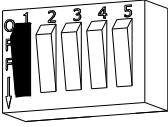
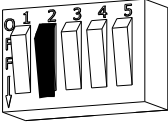
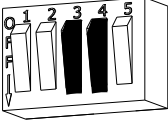

Figure 5. Component Locations



YouTube Channel: SecuritronAccess
Component Configuration
<http://tinyurl.com/M380video1>

Table 1. Component Label, Name, Selection, and Position

Component Label	Component Name	Selection	Position	
<p style="text-align: center;">SW3</p> 	<p>DIP Switch SW3.1: LED Enable</p> <p>Position 1 setting of the DIP switch enables or disables the display of the LED for lock status.</p>	<p>ON = LED ENABLED (default setting)</p>	<p>Position 1 ON (default)</p>	
		<p>OFF = LED DISABLED</p>	<p>Position 1 OFF</p>	
<p style="text-align: center;">SW3</p> 	<p>DIP Switch SW3.2: LED Color Select</p> <p>Position 2 setting of the DIP switch controls the color of the LED output. Output options are red or green.</p>	<p>ON = SECURE = RED</p>	<p>Position 2 ON</p>	
		<p>OFF = SECURE = GREEN (default setting)</p>	<p>Position 2 OFF (default)</p>	
<p style="text-align: center;">SW3</p> 	<p>DIP Switch SW3.3, SW3.4:</p> <p>NOTE: If the system is using an access control system, the relock timer must be set to a minimum time.</p> <p>Relock Delay Timer:</p> <p>The Auto Relock Delay can be adjusted by selecting a time delay with position 3 and position 4 of SW3.</p>	<p>1/2 second delay (default)</p>	<p>Position 3 OFF</p>	<p>Position 4 OFF</p>
		<p>3 second delay</p>	<p>Position 3 OFF</p>	<p>Position 4 ON</p>
		<p>7 second delay</p>	<p>Position 3 ON</p>	<p>Position 4 OFF</p>
		<p>15 second delay</p>	<p>Position 3 ON</p>	<p>Position 4 ON</p>

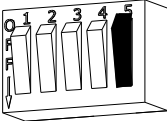
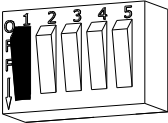
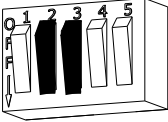
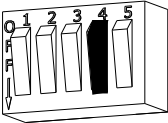
Component Label	Component Name	Selection	Position	
SW3 	DIP Switch SW3.5: PIR Model Position 5 is set by the factory. This switch should not be changed	PIR Model	Position 5 ON	
		Non-PIR Model	Position 5 OFF	
SW1 	DIP Switch SW1.1: PIR Sensitivity Position 1 setting of the DIP switch sets the PIR Sensitivity.	Medium Sensitivity (default setting)	Position 1 OFF (default)	
		High Sensitivity	Position 1 ON	
SW1 	DIP Switch SW1.2, 1.3: PIR Cone Adjustment Positions 2 and 3 of SW1 adjust the PIR sensing cone.	Wide Beam (default)	Position 2 OFF	Position 3 OFF
		Narrow Beam	Position 2 ON	Position 3 ON
		Narrow Plus Left	Position 2 ON	Position 3 OFF
		Narrow Plus Right	Position 2 OFF	Position 3 ON
SW1 	DIP Switch SW1.4: PIR Ambient Light Compensation Can be enabled with SW1.4	Ambient Light Compensation Off (default)	Position 4 OFF	Position 4 OFF
		Ambient Light Compensation ON	Position 4 ON	Position 4 ON

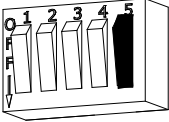
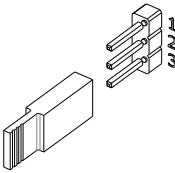
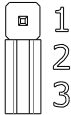
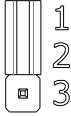
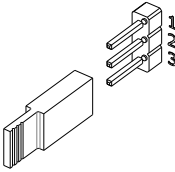
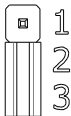
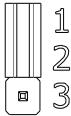
Component Label	Component Name	Selection	Position
<p data-bbox="168 164 221 183">SW1</p> 	<p data-bbox="320 164 529 183">DIP Switch SW1.5:</p> <p data-bbox="320 220 529 240">External PIR Input</p> <p data-bbox="320 277 529 362">External input at J6 can be enabled at SW1.5</p>	<p data-bbox="564 164 671 183">DISABLE</p> <p data-bbox="564 204 703 248">External PIR Input</p>	<p data-bbox="762 164 923 224">Position 5 OFF (default)</p>
		<p data-bbox="564 282 671 302">ENABLE</p> <p data-bbox="564 323 703 367">External PIR Input</p>	<p data-bbox="762 302 912 321">Position 5 ON</p>
<p data-bbox="168 412 210 431">JP1</p> 	<p data-bbox="320 412 540 621">Jumper 1: Alternate (REX) Output</p> <p data-bbox="320 480 540 621">A 3-pin jumper that controls the output setting for Alternate (REX) Output at Terminal Block J7.</p>	<p data-bbox="564 412 724 456">(NO) Normally Open</p> <p data-bbox="564 477 703 586">Circuit Open, Circuit closes when REX active</p>	
		<p data-bbox="564 634 724 678">(NC) Normally Closed</p> <p data-bbox="564 699 724 808">Circuit Closed when Door is Closed (default setting)</p>	
<p data-bbox="168 846 210 865">JP3</p> 	<p data-bbox="320 829 434 849">Jumper 3:</p> <p data-bbox="320 886 444 906">BondSTAT</p> <p data-bbox="320 943 458 963">Mode Select</p> <p data-bbox="320 1000 540 1182">A 3-pin jumper that controls the output setting for the BondSTAT in Terminal Block J8 Position 1 & 2.</p>	<p data-bbox="564 846 724 889">(NO) Normally Open</p> <p data-bbox="564 911 703 987">Circuit Open when Door is Closed</p>	
		<p data-bbox="564 1029 724 1073">(NC) Normally Closed</p> <p data-bbox="564 1094 724 1203">Circuit Closed when Door is Closed (default setting)</p>	

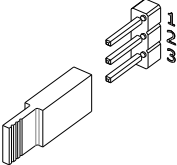
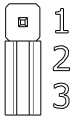
Component Label	Component Name	Selection	Position
<p data-bbox="168 164 213 185">JP4</p> 	<p data-bbox="320 155 429 178">Jumper 4:</p> <p data-bbox="320 212 469 235">Door Position</p> <p data-bbox="320 269 458 292">Mode Select</p> <p data-bbox="320 326 529 542">A 3-pin jumper that controls the output setting for the Door Position Switch (DPS) in Terminal Block J12 Position 1 & 2.</p>	<p data-bbox="564 164 724 217">(NO) Normally Open</p> <p data-bbox="564 233 708 319">Circuit Open when Door is Closed</p>	
<p data-bbox="174 586 206 607">J9</p>	<p data-bbox="320 586 504 639">Terminal Block 9 Tamper Switch</p>	<p data-bbox="564 586 969 732">A 2-wire terminal block providing a signal which changes state as determined when the cover is sensed to be removed. (Circuit is Normally Closed with cover in place).</p>	
<p data-bbox="174 760 206 781">J3</p>	<p data-bbox="320 760 504 846">Terminal Block 3 Magalock Input Power</p>	<p data-bbox="564 760 958 906">A 2-wire terminal block providing connection to a 12 or 24 VDC power supply for the main Magalock operation. Position 1 = (+) Positive. Position 2 = (-) Negative.</p>	
<p data-bbox="174 933 206 954">J2</p>	<p data-bbox="320 933 504 1019">Terminal Block 2 Auxiliary Input Power</p>	<p data-bbox="564 933 969 1079">A 2-wire terminal block providing connection to the power supply for the auxiliary components (PIR and/or Camera). Position 1 = (+) Positive. Position 2 = (-) Negative.</p>	
<p data-bbox="178 1107 210 1128">J8</p>	<p data-bbox="320 1107 504 1161">Terminal Block 8 BondSTAT</p>	<p data-bbox="564 1107 937 1253">A 2-wire terminal block providing a contact in which (NO/NC) state change is determined by Jumper 3 when the BondSTAT (magnetic bond) is interrupted.</p>	
<p data-bbox="174 1281 217 1302">J12</p>	<p data-bbox="320 1281 519 1367">Terminal Block 12 Door Position Switch</p>	<p data-bbox="564 1281 948 1427">A 2-wire terminal block providing a contact in which (NO/NC) state change is determined by Jumper 4 based on the magnet's contact with the strike plate.</p>	

Component Label	Component Name	Selection	Position
J6	Terminal Block 6 Alternate Input	A 2-wire terminal block providing a dry contact connection for external control input.	
J7	Terminal Block 7 Alternate (REX) Output	A 2-wire terminal block provides a connection for an alternate output.	
Video Connection (Camera Interface PCB)	Terminal Block Connection for Camera Signal	The included Balun and BNC cable adapter can be used to route wiring through either side of the Maglock housing for connection to a surveillance system.	

Documenting the Configuration Settings

NOTE: The Board Settings are now complete.

1. COPY the settings onto the adhesive-backed circuit board settings label enclosed with the mounting hardware packet (see Figure 6, "M380 Settings").

M380 Settings		www.securitron.com 1-800-624.5625	
DIP Switch 3 (SW3.1) LED Enable	ON=ENABLED	OFF=DISABLED	
DIP Switch 3 (SW3.2) LED SECURE Color	ON=RED	OFF=GREEN	
*Jumper 3 (JP3) Bond Select Mode	1-2=NC	2-3=NO	
*Jumper 4 (JP4) Door Position Mode	1-2=NC	2-3=NO	
* DIP Switch 3 (SW3.3) Auto Relock Delay	ON=ENABLED	OFF=DISABLED	
*(SW3.4 and SW3.5) Delay (in seconds)	1/2 3 7 15		
* available on M380BD models only			

Figure 6. M380 Settings

NOTE 1: The figure above shows the Default settings. Settings may vary based on checklist.

NOTE 2: The settings information is required if the Magnalock needs to be inspected, serviced, or replaced.

2. COMPLETE the label and AFFIX to the inside cover of the Magnalock (see Figure 7, "Magnalock Settings Label.")

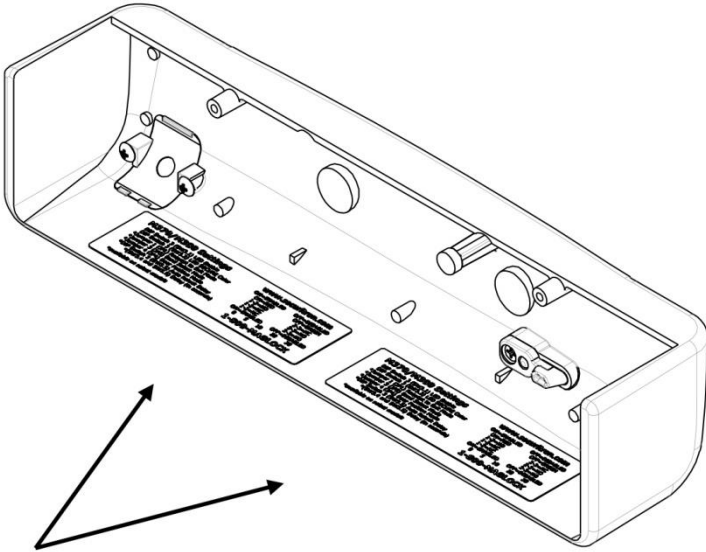

Figure 7. Magnalock Settings Labels

Installing the Magnalock

1. REMOVE the two (2) screws securing lock to mounting bracket and SLIDE the bracket from the top of the lock chassis (see Figure 8, "Removing the Securing Screws").

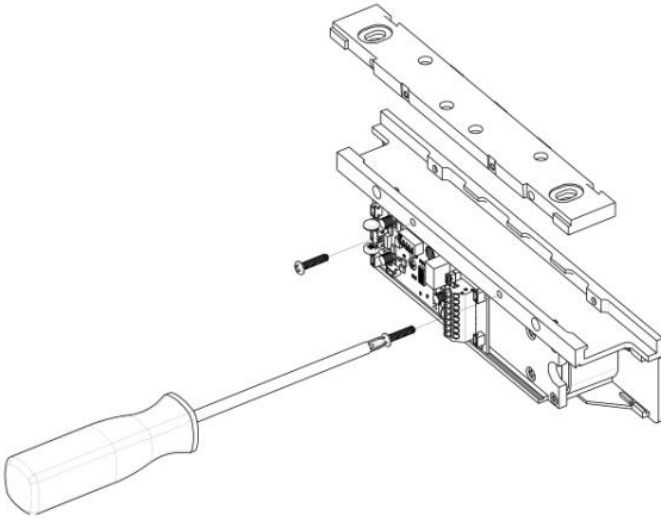

Figure 8. Removing the Securing Screws

2. PINCH and INSERT spacers flush into the dovetail slots of the lock-mounting bracket (see Figure 9, "Inserting the Spacers").

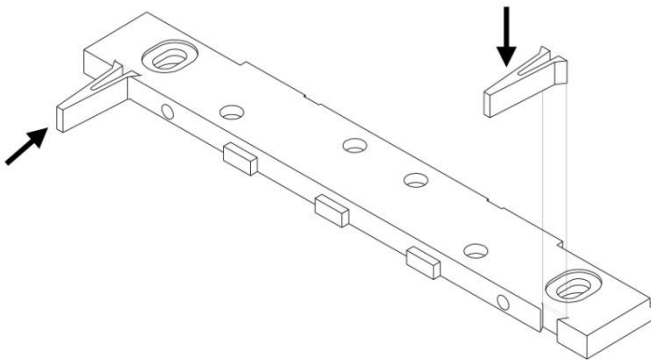

Figure 9. Inserting the Spacers

3. PERFORM the following to mark the mounting holes.
 - a. PROTECT the door and frame surfaces from any possible damage during marking and drilling by using masking tape.
 - b. PLACE the lock bracket on the secure side of the door against the frame stop, towards the side of the door that does not have hinges, and has a minimum of 7/8" clearance from the frame.
 - c. CLOSE the door and ADJUST the bracket so that the spacers rest against the door.
 - d. MARK the frame through the two (2) oblong bracket mounting holes (see Figure 10, "Marking the Frame").

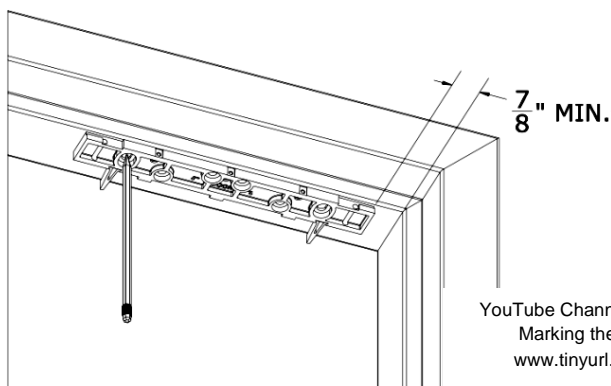

Figure 10. Marking the Frame

4. MARK the frame for wire feed-through hole at the end closest to where the wire run will be accessed.
5. ENSURE these holes are toward the rear edge of the mounting bracket and adjacent to the end of the bracket (see Figure 11, "Position of Wire Feed-Through Holes").

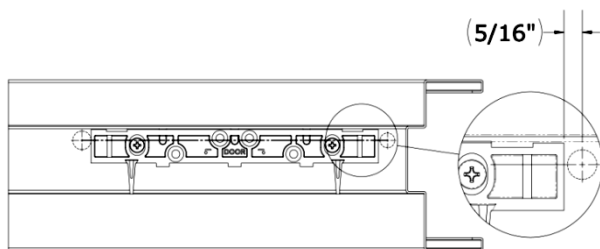

Figure 11. Position of Wire Feed-Through Holes

6. REMOVE mounting bracket from frame when drilling holes.

NOTE 1: Steps 7–9c are performed if installing on metal door frame.

NOTE 2: Steps 10–11 are performed if installing on a wood door frame.

7. DRILL two (2) 3/8" diameter holes at bracket-mounting hole marks (see Figure 12, "Drilling the Bracket Mounting Holes"); DO NOT oversize.

8. USE a step bit or pilot hole first to ensure a snug fit for the blind nuts.

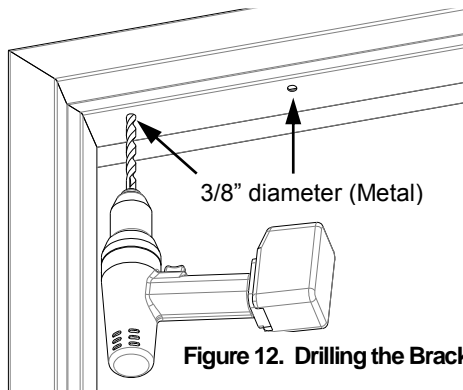

Figure 12. Drilling the Bracket Mounting Holes

NOTE: Blind nuts provide a highly secure and tamper resistant system for mounting and are the mounting hardware provided for this unit.

9. INSTALL blind nuts into each 3/8" diameter hole using the provided tool (see Figure 13, "Installing the Blind Nuts").

- HOLD the collapsing nut with a 1/2" box end wrench.
- MAINTAIN pressure on the mounting surface, TIGHTEN the cap screw using a 3/16" hex wrench, and COLLAPSE the blind nut.
- GO TO Step 12.

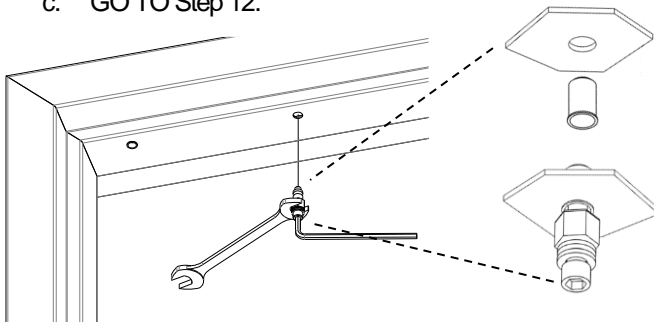

Figure 13. Installing the Blind Nuts



YouTube Channel: SecuritronAccess
Blind Nut Installation
www.tinyurl.com/M380video3

10. DRILL two (2) 3/16" diameter mounting holes by 1-1/4" deep at bracket-mounting hole marks (see Figure 14, "Drilling the Mounting Holes").

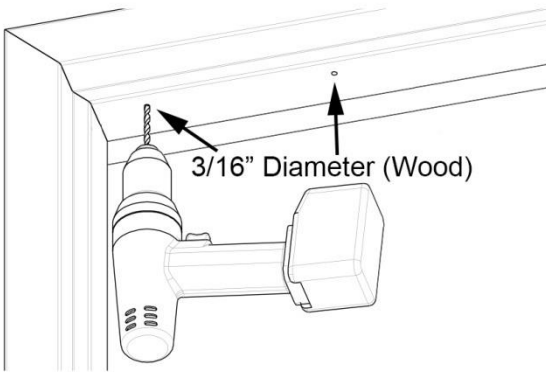

Figure 14. Drilling the Mounting Holes

11. DRILL wire access holes (1/2" recommended), as needed, on one or both sides of the bracket (see Figure 15, "Drilling the Wire Access Holes").

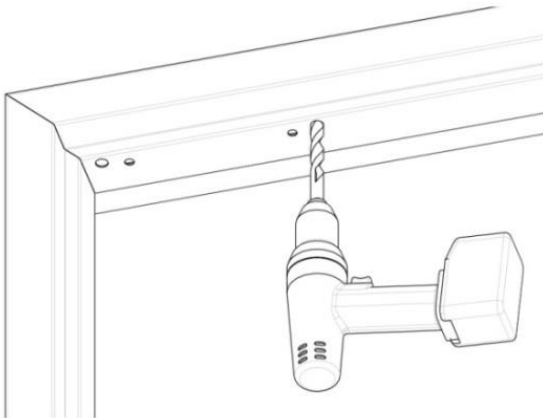

Figure 15. Drilling the Wire Access Holes

12. Temporarily **INSTALL** the bracket with spacers against the closed door using a Phillips screwdriver (see Figure 16, “Installing the Bracket”).

NOTE: Step 13a applies to metal frames.

- a. USE two (2) 1/4-20 X 1” Phillips Pan Head Screws and **APPLY** included thread lock to screw threads.

NOTE: Step 13b applies to wood frames.

- b. USE two (2) #12 X 1-1/2” Type A, Phillips Pan Head Screws.

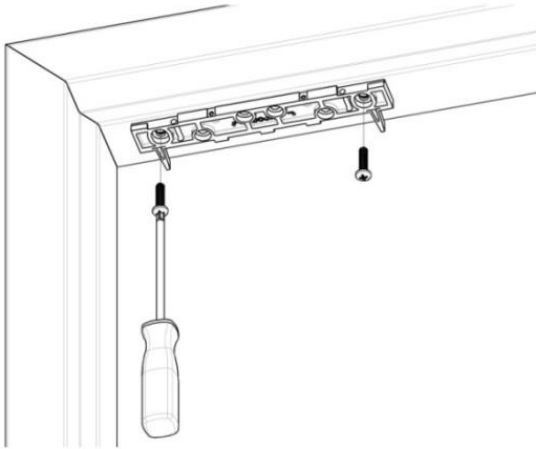

Figure 16. Installing the Bracket

Installing the Strike

1. **CLOSE** the door and **PLACE** the template between the bracket spacers.
2. **MARK** the strike plate hole locations (see Figure 17, “Marking the Strike Plate Hole Locations”).

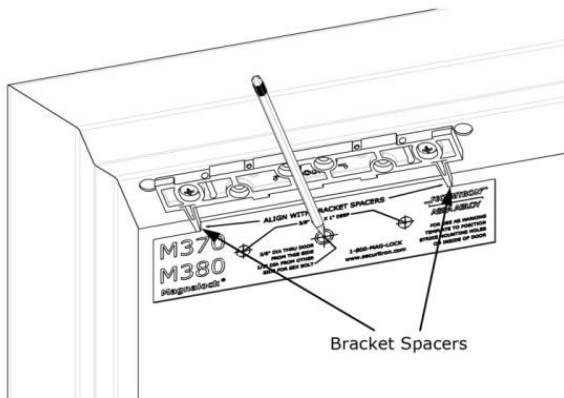

Figure 17. Marking the Strike Plate Hole Locations



YouTube Channel: SecuritonAccess
 Marking the Strike Plate Hole Locations
www.tinyurl.com/M380video4

3. REMOVE the bracket spacers from the bracket.

From INSIDE the door:

4. DRILL one (1) 3/8" diameter hole for the sex bolt through the door at the strike mounting center mark.
5. DRILL two (2) 3/8" diameter x 1" deep holes at each side mark for the strike alignment roll pins, but DO NOT DRILL through the door (see Figure 18, "Drilling the Inside Door Holes").

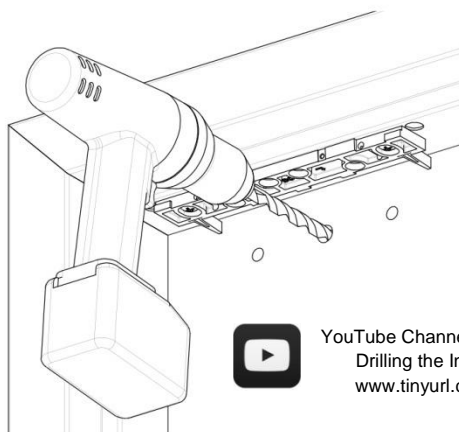

YouTube Channel: SecuritonAccess
 Drilling the Inside Door Holes
www.tinyurl.com/M380video5

Figure 18. Drilling the Inside Door Holes

From OUTSIDE the door:

6. For a **Hollow Metal Door**, DRILL out the 3/8" diameter strike mounting hole to 1/2" diameter in the outer wall only.
7. For a **Solid Wood Door**, DRILL out 3/8" diameter strike mounting hole to 1/2" diameter; DRILL completely through door (see Figure 19, "Drilling the Outside Door Holes").

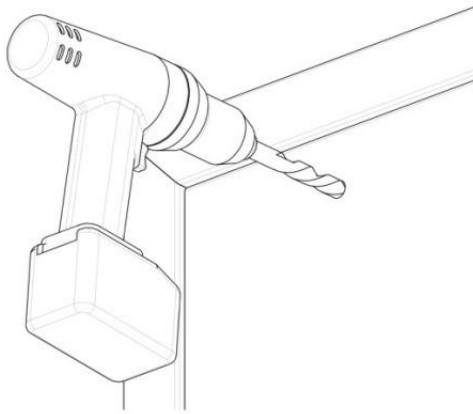

Figure 19. Drilling the Outside Door Holes

8. PERFORM the following to install roll pins into strike plate.
 - a. REMOVE the two (2) roll pins from the hardware packet.
 - b. INSERT a roll pin into each of the holes in back of strike.
 - c. Gently TAP into place using a hammer (see Figure 20, Inserting the Roll Pins”).

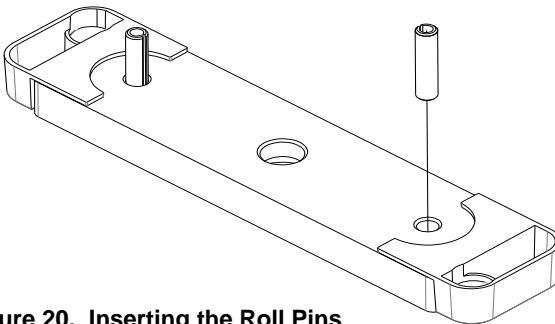

Figure 20. Inserting the Roll Pins

NOTE: Figure 21, “Securing the Strike Plate,” provides illustration for the following steps.

9. PERFORM the following to secure strike plate to the door.
 - a. APPLY the included thread lock compound to 5/16-18 X 1-3/4” flat head socket screw.
 - b. INSERT the 5/16-18 X 1-3/4” flat head socket screw through the strike bushing, strike plate, two (2) neoprene washers, door and into the sex bolt as illustrated.
 - c. TIGHTEN the screw into sex bolt using a 3/16” hex wrench; and while tightening, gently TAP the head of sex bolt until the head sits flush with the door using a hammer.

NOTE: The strike should rock on the neoprene washers for proper function and optimal holding force.

- d. DO NOT OVER-TIGHTEN the assembly; the neoprene washers should not be compressed.

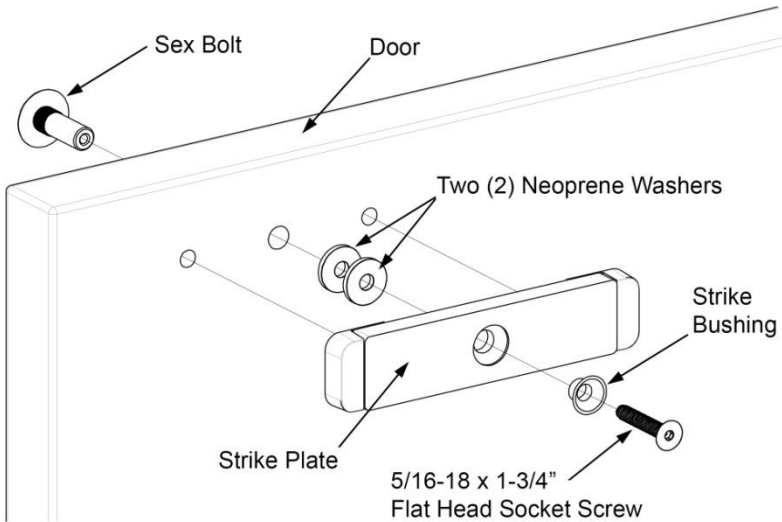

Figure 21. Installing the Strike Plate



YouTube Channel: SecuritronAccess
Installing the Strike Plate
www.tinyurl.com/M380video6

Assembling the Lock to the Bracket and Adjusting, as Necessary

NOTE: Figure 22, “Assembling the Lock to the Bracket and Adjusting,” provides illustration for the following steps.

1. **LOOSEN** the two screws securing the mounting bracket to the door frame so that the bracket can move.
2. **SLIDE** the lock onto the mounting bracket and **TEST FIT** against the strike plate with the door closed; **SLIDE** the lock so that the entire face makes contact with the strike plate.
MARK back edge of mounting bracket at each end and **REMOVE** the lock from the bracket.



YouTube Channel: SecuritronAccess
Assembling the Lock to the Bracket
www.tinyurl.com/M380video7

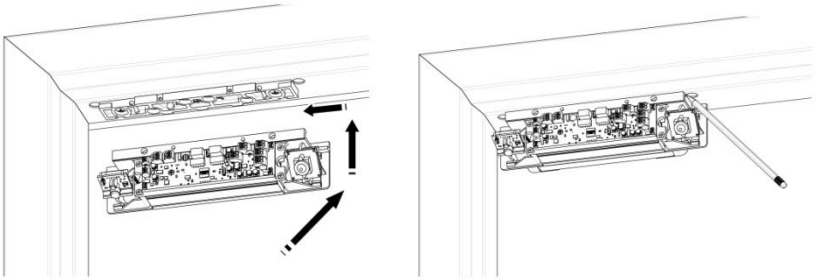

Figure 22. Assembling the Lock to the Bracket and Adjusting

5. **ENSURE** that the mounting bracket aligns with the marks, and **TIGHTEN** the mounting screws (see Figure 23, “Tightening the Mounting Screws”).

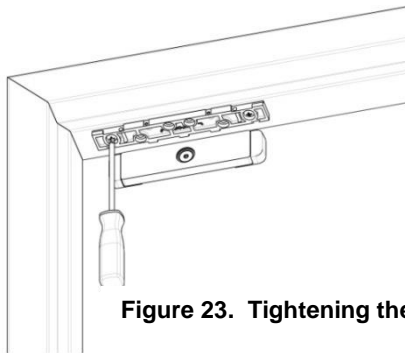

Figure 23. Tightening the Mounting Screws

6. Using the mounting bracket as a template, DRILL the four remaining holes in the frame for the anchor screws as follows (see Figure 24. Drilling the Anchor Screw Holes”):

- Metal Frames have 3/16” diameter holes.
- Wood Frames have 7/32” diameter holes.

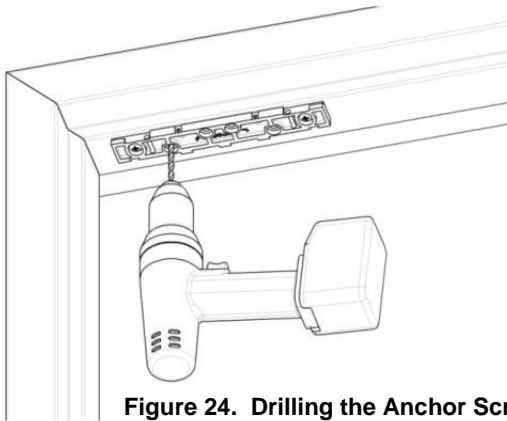

Figure 24. Drilling the Anchor Screw Holes

7. INSTALL the four (4) anchor screws using a Phillips screwdriver (see Figure 25, “Installing the Anchor Screws”):

- Metal Frames use #12 X 1-1/2” Type A, Phillips Pan Head Screws
- Wood Frames use #14 X 3” Type A, Pan Head Screws



Figure 25. Installing the Anchor Screws

Performing Final Installation

NOTE: The edge of the lock chassis must be flush with the end of the mounting bracket when centered (see inset).

1. INSERT the top of the Magnalock chassis at the end of the mounting bracket, and SLIDE the lock chassis to the center of the bracket (see Figure 26, "Performing Final Installation").



YouTube Channel: SecuritronAccess
Final Installation
www.tinyurl.com/M380video8

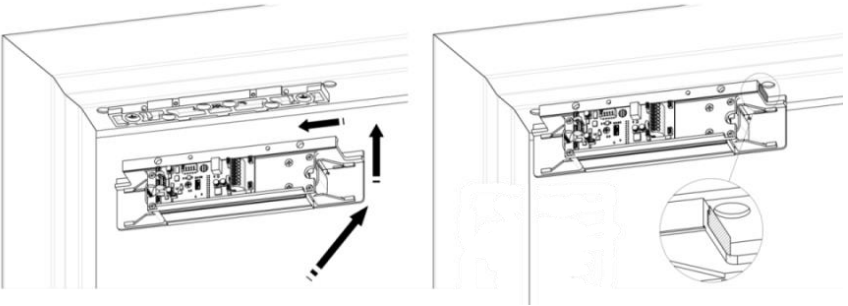

Figure 26. Performing Final Installation

2. INSTALL the two (2) 6-32 X 3/4" Phillips pan head screws to secure the lock chassis to the mounting bracket using a Phillips screwdriver (see Figure 27, "Securing the Lock Chassis to the Mounting Bracket").

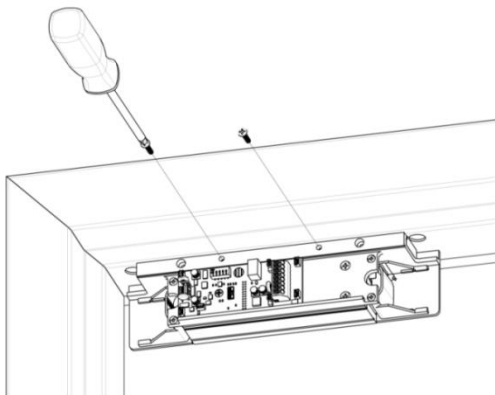

Figure 27. Installing the Lock Chassis to the Mounting Bracket

Performing the Final Wiring

NOTE 1: End user and installer are liable for Fire and Building code compliance.

NOTE 2: A small screwdriver has been included to help make connections to the terminal blocks, as required.

1. PULL wires/cables through the wire feed-through hole(s) that are drilled in the frame, and CONNECT wiring using the Figure 29, "Wiring for M380 BDC/BDC2," and Figure 30, "Wiring for M380 BDCX/BDC2X/BDX," as guides.

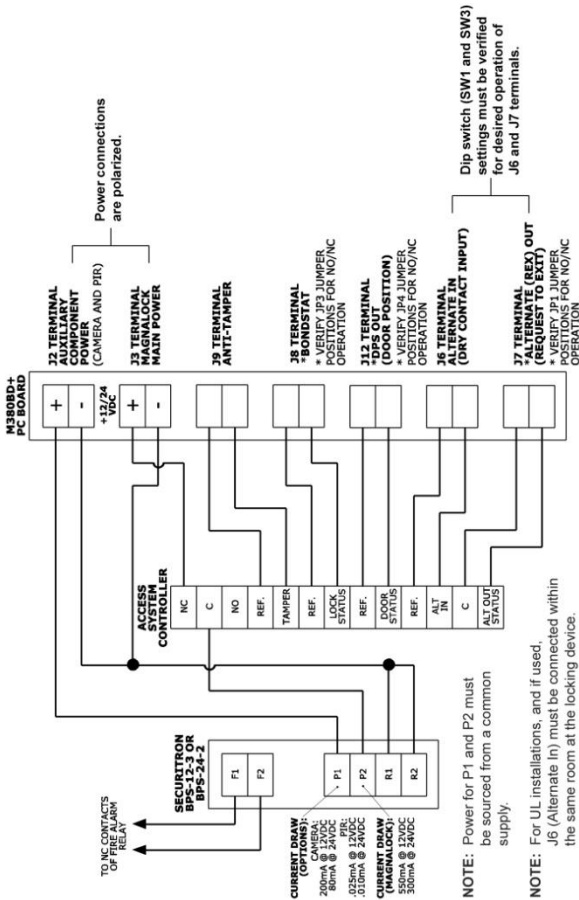

Figure 29. Wiring for M380 BDC/BDC2

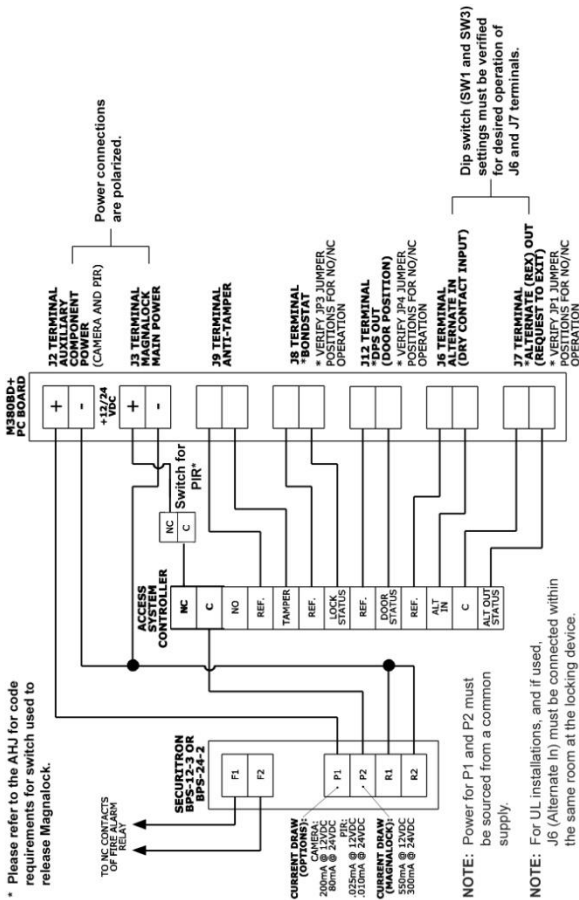

Figure 30. Wiring for M380 BDCX/BDC2X/BDX

NOTE 1: Steps 2–6 are performed for M380 models with the PIR feature.

NOTE 2: PIR control features are accessed by the DIP Switches SW3 and SW1 settings.

2. SET the relock delay timer using DIP Switch SW3, Positions 3 and 4, as required.

NOTE: Figure 31, “PIR Sensitivity and Cone Adjustment,” provides illustration to Steps 3 and 4.

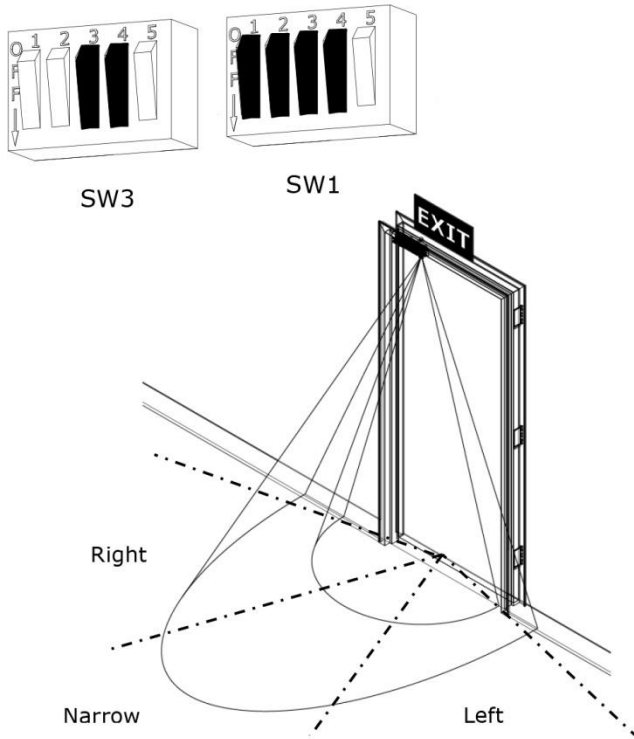

Figure 31. PIR Sensitivity and Cone Adjustment

3. SET the PIR sensitivity using DIP Switch SW1, Position 1, as required.
4. SET the PIR Cone Adjustment width using DIP Switch SW1, Positions 2 and 3, as required.
5. ENABLE or DISABLE the PIR ambient light compensation feature using DIP Switch SW1, Position 4, as required.
6. REPOSITION the PIR sensor PC board in the modular bracket, as necessary, for increased range (see Figure 32, “Repositioning the PIR”).

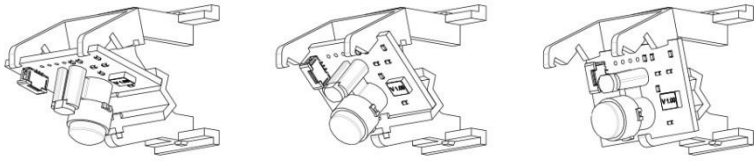

Figure 32. Positioning the PIR

NOTE 1: Step 7 is performed for M380 models with the camera feature.

NOTE 2: The camera module features an interface PC board which includes a two-position terminal block.

NOTE 3: A BNC straight adapter is also included for connections to a male BNC connector (see Figure 30, “Connecting the Camera”).

- CONNECT the camera to the security system with a two-wire (twisted pair) from the two-position interface board terminal block to the included video transceiver balun (see Figure 33).

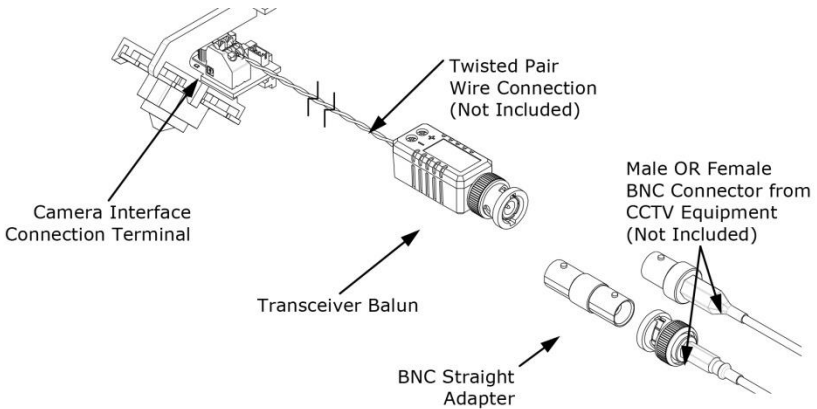

Figure 33. Connecting the Camera

- After installation and wiring have been completed, RE-INSTALL the lock cover through the lock chassis using the two (2) phillips screws (see Figure 34, “Installing the Lock Cover”).

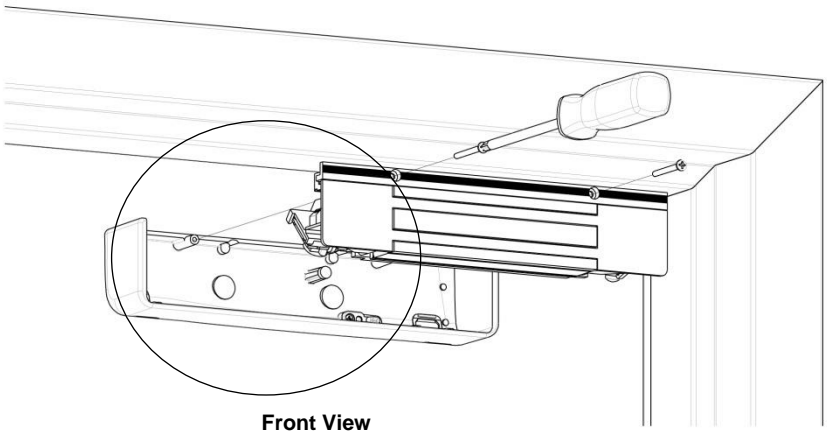
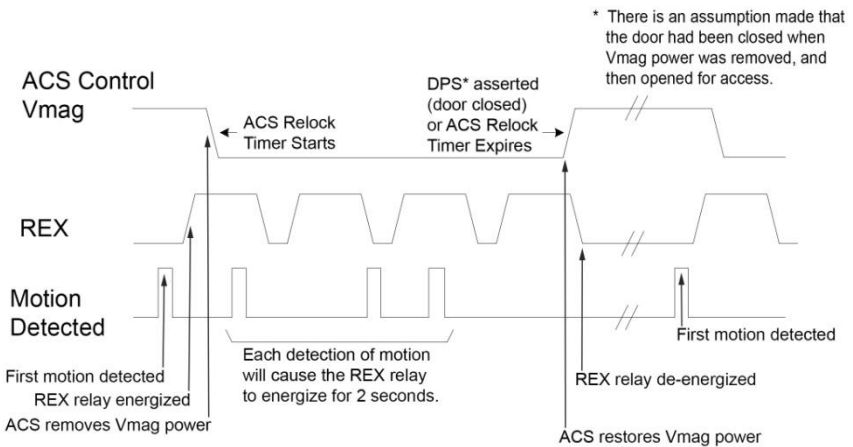

Figure 34. Installing the Lock Cover

Magnalock Operation With Access Control System

NOTE: The Magnalock relock timer is required to be set to minimum.



Magnalock Operation With Local Control

NOTE: The Magnalock relock timer is required to be set to minimum.

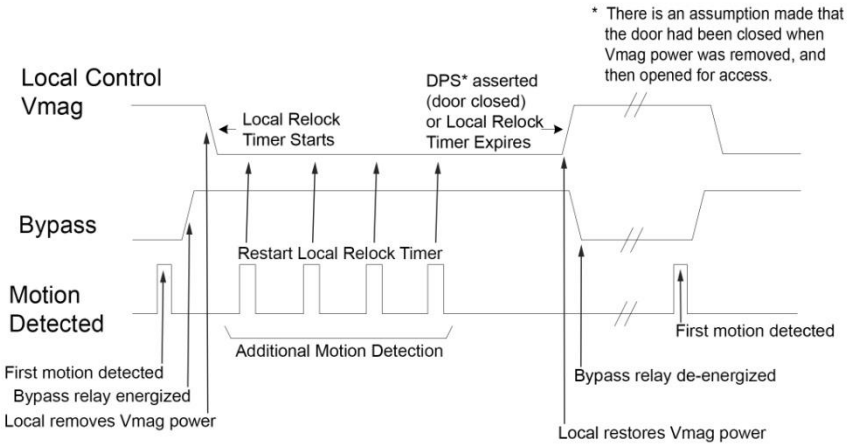

Magnalock Maintenance

1. PERFORM the following to complete a visual inspection.
 - a. INSPECT the rubber washers for elasticity and proper pivoting; and TIGHTEN, as required.
 - b. INSPECT for build-up of debris on the Magnalock and strike armature.
 - c. INSPECT for rust on the Magnalock and strike plate armature; CLEAN, as required.

Proper Cleaning Methods

2. APPLY rubbing alcohol onto a clean cloth and thoroughly WIPE DOWN the Magnalock and strike plate armature.

NOTE 1: Cleaning once a year is recommended.

NOTE 2: Petroleum-based products should never be used for cleaning.

NOTE 3: Steel wool-based scrub pads or sandpaper should never be used for cleaning.

3. CLEAN every three to six months where rusting occurs.
4. USE a plastic dishwashing scrub pad to aid in the removal of rust.

Troubleshooting Guide

POSSIBLE ISSUES	TROUBLESHOOTING TIPS
<p>NOTE: When Vaux of a M380 (all M380BDC/C2/X variants) reaches 7.5V, the lock releases and LV flash commences until the system recovers or Vaux has fallen to a point causing the system to be in a brown-out condition.</p>	
<p>No power or low power</p>	<p>CONFIRM voltage and current at Magnalock to specification.</p> <p>NOTE: Power must be at least <u>Rectified</u> and <u>Filtered</u> to meet minimum electrical specifications. AC, Half Wave, and Full Wave power is unacceptable.</p> <p>CHECK that the DC power source is Full Wave Rectified.</p>
<p>Reduced Holding Force</p>	<p>CHECK strike plate position and orientation.</p> <p>CLEAN surfaces and CHECK for obstructions.</p> <p>CONFIRM voltage and current at Magnalock to specification.</p> <p>NOTE: Power must be at least <u>Rectified</u> and <u>Filtered</u> to meet minimum electrical specifications. AC, Half Wave, and Full Wave power is unacceptable.</p> <p>CHECK that the DC power source is Full Wave Rectified.</p>

LED Error Codes

NOTE: The position 1 switch of DIP switch SW3 must be set to the ON position (LED ENABLED) for error codes to be visible.

CODE	STATE	SOLUTION
SECURE selected color, on continuously	Normal Operation with Door Closed	System working normally, SECURE selected color can be selected with position 2 switch of SW3. See page 4.
NON-SECURE selected color, on continuously	Normal Operation with Door Open	System working normally.
RED/GREEN continuous flash	Processor Error	CHECK all connections, if error persists replace unit.
AMBER Continuous flash	Low Voltage Condition (Occurs below 8.2V). MagnaLock is disabled.	CHECK voltage and current at Magnalock connections. CHECK DC Power Source is Full Wave Rectified.
Solid AMBER	Any situation, DPS or Bond.	CHECK strike plate position and orientation. CLEAN surfaces and check for obstructions.
Off	LED disabled	CHECK voltage and current at Magnalock connections. CHECK that LED is enabled with position 1 switch of SW3 is in the OFF position.

Securitron

Phoenix, AZ

Tel: 1.800.624.5625

Mon-Fri: 6:00am - 4:00pm PDT

Fax: 1.800.232.7329

www.securitron.com

techsupport@securitron.com



ASSA ABLOY, the global leader
in door opening solutions