



P516-129



AD-200

Offline lock user guide

Instructions for AD-Series offline locks

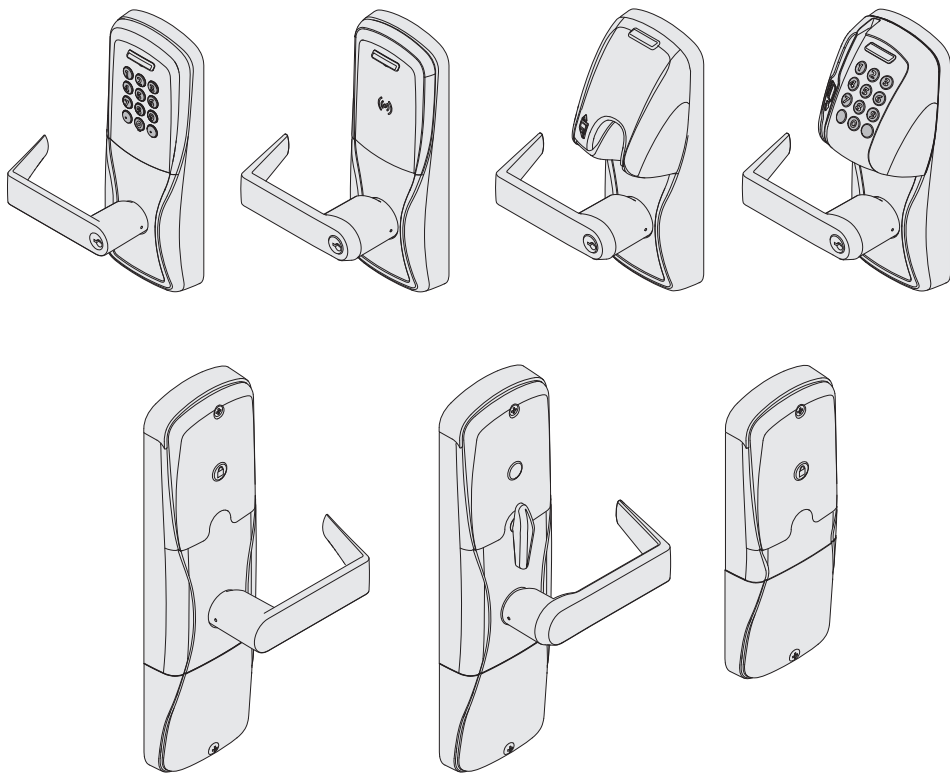

Contents

Overview	3
Lock functions	4
Getting started	4
Schlage Utility Software (SUS)	4
Construction access mode	5
Locks with keypads – Construction access mode.....	5
Locks with card readers – Create a master construction credential	5
Locks with card readers – Add construction access mode user credentials	5
Cancel construction access mode	6
Credential types and functions	6
Credential forms.....	6
Manual programming instructions.....	7
PROGRAMMING credentials.....	7
NORMAL USE credentials	8
TOGGLE credentials.....	9
FREEZE credentials.....	10
PASS THROUGH credentials	11
OTHER programming	12
Error codes	12
Test lock operation.....	13
Mechanical test	13
Electronic test.....	13
Normal lock operation.....	13
Wired remote release feature	14
System and hardware requirements	14
Switch specifications, wire specifications and routing.....	14
Wired remote release operation.....	14
Wired remote release button action	14
Reset to factory defaults	15
Level 1 factory default reset.....	15
Level 2 factory default reset.....	15
Batteries	16
To install or replace batteries	16
Low battery indications.....	17
Battery failure modes	17
External power supply	17
LED Reference	18
Schlage button	18
Optional Inside Push Button (IPB)	18
Troubleshooting	19
FCC/IC Statements.....	20

Overview

The Schlage AD-200 is an off-line electronic lock in the AD-Series product line.

- May be powered by batteries or connected to external power using a UL294 or ULCS318/ULCS319 listed power supply capable of sourcing at least 250 mA @ 12 or 24 VDC. See *Batteries* on page 16, or *External power supply* on page 17 for more information.
- Outside lever is normally locked.
- Inside lever always allows egress.
- The lock maintains an audit trail of events.
- Configured using the Schlage Utility Software (SUS).

Outside

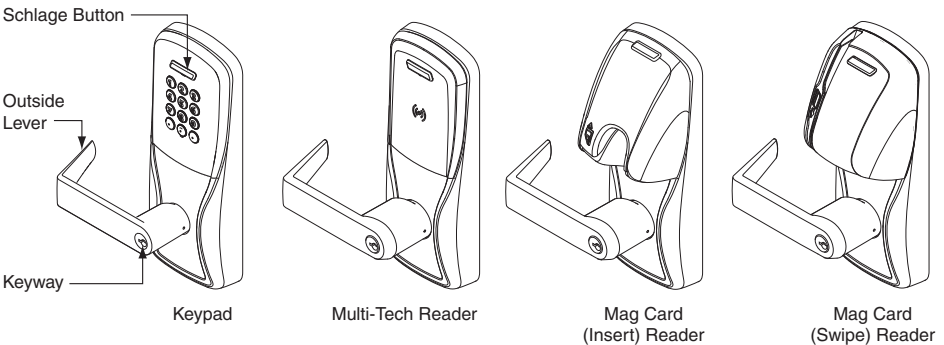

Inside

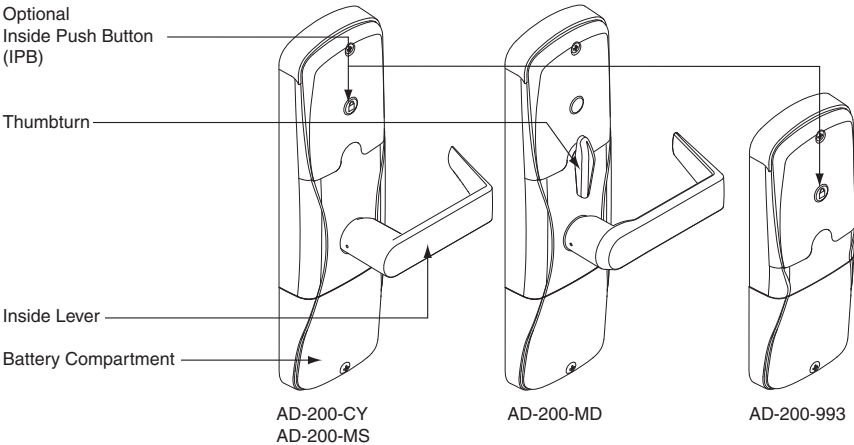

Additional AD-200 reader options: Mag + Keypad, Multi-Tech + Keypad

Note: Proximity card (PR, PRK) ONLY and Smart card (SM, SMK) ONLY readers have been discontinued and replaced by the Multi-Tech (MT, MTK) readers that provide all the same functionality as the original Proximity and Smart card readers in a single credential reader.

This product is compliant of UL294 and ULCS319 standard. This product's compliance would be invalidated through the use of any add-on, expansion, memory or other module that has not yet been evaluated for compatibility for use with this UL Listed product, in accordance with the requirements of the Standards UL294 and ULCS319. This product has been evaluated for CAN/ULC-S319 Class 1.

UL294 Access Control Levels tested to: Destructive Attack - Level 1; Line Security - Level 1; Endurance - Level 4; Standby Power - Level 1.

Lock functions

The AD-200 is available in one of four functions:

Privacy (40): Lockset is normally secure. Pressing the Inside Push Button or extending the deadbolt will disable normal electronic access from the outside. Opening the door, retracting the deadbolt or pressing the Inside Push Button a second time deactivates the privacy status.

Office (50): Lockset is normally secure. Inside Push Button may be used to select passage or secured status.

Apartment (60): Lockset is normally secure. Inside Push Button is used to select passage or secure status. While in the secure state, opening the door or pressing the Inside Push Button causes the lockset to toggle unsecured. The door must be closed and a valid credential presented to secure the lockset from the outside.

Classroom/Storeroom (70): Lockset is normally secure. Valid toggle credentials may be used to change to a passage or secure status.

Getting started

Follow these steps when setting up a new lock.

1. Install the lock. See the installation guide that came with the lock, or visit www.allegion.com/us for more information.
 2. Make sure the batteries are installed properly. See *Batteries* on page 16 for instructions.
 3. Configure the master construction credential (where applicable). See *Construction access mode* on page 5 for more information. The lock should remain in construction access mode until you are ready to set up the rest of the system.
 4. Test the lock for proper mechanical and electronic operation. See *Test lock operation* on page 13 for more information.
 5. When ready to set up for normal use, program the user credentials. See *Credential types and functions* on page 6.
- ① **Programming the lock with the SUS will remove all credentials that were added using the master construction credential.**
6. Consult the SUS user guide for information about configuring the lock.
 7. Familiarize yourself with the information in this guide.

Save this user guide for future reference.

Schlage Utility Software (SUS)

The Schlage Utility Software is used for programming and setup only.

The SUS is used to configure locks. This includes transferring data files between the access control software and locks. For information about the SUS, refer to the SUS user guide.

Construction access mode

Construction access mode is used to allow access before the lock has been programmed, and for testing purposes.

- Enabled by default.
- The lock will remain in construction access mode until the mode is cancelled as described below.
- No audits are captured while lock is in construction access mode.
- Use the same master construction credential for all the locks in the facility.
- If you present the first card to a new lock to create the master construction credential and the card is not accepted, the lock has either been programmed or already has a master construction credential.
- If the master construction credential cannot be located, or to put the lock back into construction access mode, reset the lock to factory settings (see page 15 for details).

Locks with keypads – Construction access mode

In the factory default state, locks with keypads have a default PIN of 13579 and “#”, which can be used for installation, testing and construction access. To test, enter default PIN. The Schlage button will blink and the lock will unlock.

The default PIN, 13579 and “#” is automatically deleted when a construction access user credential is added to the lock, or a new programming credential is created, or the lock is programmed with the SUS.

Locks with card readers – Create a master construction credential

The master construction credential is used to program construction access mode credentials.

To create a master construction credential:

1. Press and hold the Schlage button while presenting a credential.
2. The Schlage button will blink green on the left and right as confirmation.
3. Use this card to add construction access mode user credentials.

ⓘ **The master construction credential will not grant access. It is used only to add additional credentials.**

Locks with card readers – Add construction access mode user credentials

Construction access mode credential type	Steps to add construction access mode user credentials				
	1	2	3	4	5
Normal use construction credential Unlocks the lock for relock delay period	Present master construction credential to reader →	Green LEDs blink →	Present user credential within 20 seconds →	Green LEDs blink and credential is added →	Repeat steps 3 and 4 for additional credentials.
Toggle construction credential Changes the state of lock from locked to unlocked or vice versa	Present master construction credential to reader →	Green LEDs blink →	Press and hold Schlage button while presenting user credential within 20 seconds →	Green LEDs blink, 2 beeps will sound and credential is added →	Credentials added with the master construction credential will have 24/7 access.

Cancel construction access mode

Do one of the following:

- Program the lock with the SUS. See the SUS user guide for more information.
- Reset the lock to factory settings. See *Reset to factory defaults* on page 15 for more information.

When construction mode is cancelled, the master construction credential and all other credentials added using the master construction credential will no longer function.

Credential types and functions

Programming credential: A card or 5 digit code used only for lock programming.

Card or PIN credentials: A card that is presented, or a 3-6 digit code entered on the keypad.

Card ID number: When adding any new card credential, a 3-6 digit code is entered prior to presenting the card. This code becomes the Card ID Number. This number can be used to delete a card credential without physically having the card. *Keep a log of all Card ID Numbers for future reference.*

Note: A unique credential must be used for each credential type described below (for example, a single credential may not be used for both normal use and toggle functions).

Credential type	Function
Programming PIN or card	Used <u>only to program</u> the lock. Does not unlock the lock.
Normal use credential	Unlocks the lock <i>momentarily</i> after a credential is presented or entered.
Toggle credential	Changes the state of the lock from locked (secured) to unlocked (unsecured), or vice versa, unless in a Freeze state.
Freeze credential	Freezes the lock in the current state. The lock remains frozen until any Freeze credential is presented again. (A pass-through credential will override a lock in frozen state as described below).
Pass-through credential	Unlocks a lock <i>momentarily</i> , regardless of state. A valid Pass-through credential can unlock a door set to any secured lockout mode (e.g., Freeze, Privacy, Time Zones, Door Auto-Locks and Holidays). The door will relock after the specified relock time.

Credential forms

Normal, toggle, freeze and pass-through credential types are used in one of three forms:

PIN credential – a 3-6 digit code entered on the keypad.

CARD credential – a card presented to the lock.

CARD + Card ID Number credential – a card (with a unique Card ID number) presented to the lock. (See a description of Card ID number above for more information.)

Steps for designating each form are in the *Manual programming instructions* on the following pages.

Manual programming instructions

Important notes:

- ① Wait for the Schlage button LEDs to stop flashing before continuing to the next step.
- ① Programming mode will time out if no entry is made in 20-25 seconds. Time out is indicated by three left and nine right red blinks of the Schlage button.
- ① An incorrect entry is indicated by a solid red left and blinking green right LED on the Schlage button. Refer to *Error codes* on page 12 to interpret error code patterns.
- ① A unique credential must be used for each credential type (for example, a single credential may not be used for both normal use and toggle functions).

PROGRAMMING credentials

To complete this action:	Perform the following steps:			
	Wait for  to stop flashing between each step!			
	1	2	3	4
Create new Programming Code (PIN)	Enter ⑨⑦⑤③①* (This is the default programming PIN)	Enter ⑦*	Enter new 5 digit Programming code and * Wait for right green light.	Reenter the new 5 digit Programming code and * Wait for confirmation: 2 right green blinks.
Create new Programming Card	Enter ⑨⑦⑤③①*	Enter ⑦*	Present new programming card.	Wait for confirmation: 2 right green blinks.

① **Note:** Before creating any credential in the following steps, determine which credential form is desired (see *Credential forms* on page 6).

NORMAL USE credentials

Note: Until a new Normal Use PIN is created, the default PIN is ①③⑤⑦⑨②

To complete this action:	Perform the following steps:					
	Wait for  to stop flashing between each step!					
	1	2	3	4	5	6
Create a Normal Use PIN	Enter Programming PIN and * OR Present Programming card	Enter ③ *	Enter new 3-6 digit PIN and * *	For another PIN, go back to step 3	Press * again to finish	Wait for confirmation: 2 right green blinks.
Create a Normal Use CARD	Enter Programming PIN and * OR Present Programming card	Enter ③ *	Enter new 3-6 digit Card ID Number and *	Wait for right green light. Present new CARD to lock.	For another CARD, go back to step 3 OR press * again	Wait for confirmation: 2 right green blinks.
Create a Normal Use CARD + Card ID Number	Enter Programming PIN and * OR Present Programming card	Enter ③ ③ *	Enter ③ ① ① *	Enter new 3-6 digit Card ID Number and * Wait for right green light.	Present new CARD to lock.	For another CARD+Card ID credential, go back to step 4 OR press * again to finish Wait for confirmation: 2 right green blinks.

① **Note:** Before creating any credential in the following steps, determine which credential form is desired (see *Credential forms* on page 6).

TOGGLE credentials

To complete this action:	Perform the following steps: Wait for  to stop flashing between each step!					
	1	2	3	4	5	6
Create a Toggle PIN	Enter Programming PIN and * OR Present Programming card	Enter ③ ③ *	Enter ① ⑨ ① *	Enter new 3-6 digit PIN and * Wait for right green light.	For another PIN, go back to step 3 OR press * again to finish	Wait for confirmation: 2 right green blinks.
Create a Toggle CARD	Enter Programming PIN and * OR Present Programming card	Enter ③ ③ *	Enter ① ⑨ ① *	Enter new 3-6 digit Card ID Number and * Wait for right green light.	Present new CARD to lock.	For another CARD, go back to step 3 OR press * again to finish Wait for confirmation: 2 right green blinks.
Create a Toggle CARD + Card ID Number	Enter Programming PIN and * OR Present Programming card	Enter ③ ③ *	Enter ③ ⑨ ① *	Enter new 3-6 digit Card ID Number and * Wait for right green light.	Present new CARD to lock.	For another CARD+Card ID credential, go back to step 4 OR press * again to finish Wait for confirmation: 2 right green blinks.

- ① **Note:** Before creating any credential in the following steps, determine which credential form is desired (see *Credential forms* on page 6).

FREEZE credentials



























To complete this action:	Perform the following steps:					
	Wait for  to stop flashing between each step!					
	1	2	3	4	5	6
Create a Freeze PIN	Enter Programming PIN and * OR Present Programming card	Enter ③ ③ *	Enter ① ① ⑤ *	Enter new 3-6 digit PIN and * Wait for right green light.	For another PIN, go back to step 3 OR press * again to finish	Wait for confirmation: 2 right green blinks.
Create a Freeze CARD	Enter Programming PIN and * OR Present Programming card	Enter ③ ③ *	Enter ① ① ⑤ *	Enter new 3-6 digit Card ID Number and * Wait for right green light.	Present new CARD to lock.	For another CARD, go back to step 3 OR press * again to finish Wait for confirmation: 2 right green blinks.
Create a Freeze CARD + Card ID Number	Enter Programming PIN and * OR Present Programming card	Enter ③ ③ *	Enter ③ ① ⑤ *	Enter new 3-6 digit Card ID Number and * Wait for right green light.	Present new CARD to lock.	For another CARD+Card ID credential, go back to step 4 OR press * again to finish Wait for confirmation: 2 right green blinks.

- ① **Note:** Before creating any credential in the following steps, determine which credential form is desired (see *Credential forms* on page 6).

PASS THROUGH credentials

To complete this action:	Perform the following steps: Wait for  to stop flashing between each step!					
	1	2	3	4	5	6
Create a Pass Through PIN	Enter Programming PIN and * OR Present Programming card	Enter ③ ③ *	Enter ① ① ⑨ *	Enter new 3-6 digit PIN and * Wait for right green light.	For another PIN, go back to step 3 OR press * again to finish	Wait for confirmation: 2 right green blinks.
Create a Pass Through CARD	Enter Programming PIN and * OR Present Programming card	Enter ③ ③ *	Enter ① ① ⑨ *	Enter new 3-6 digit Card ID Number and * Wait for right green light.	Present new CARD to lock.	For another CARD, go back to step 3 OR press * again to finish Wait for confirmation: 2 right green blinks.
Create a Pass Through CARD + Card ID Number	Enter Programming PIN and * OR Present Programming card	Enter ③ ③ *	Enter ③ ① ⑨ *	Enter new 3-6 digit Card ID Number and * Wait for right green light.	Present new CARD to lock.	For another CARD+Card ID credential, go back to step 4 OR press * again to finish Wait for confirmation: 2 right green blinks.

OTHER programming

To complete this action:	Perform the following steps:				
	Wait for  to stop flashing between each step!				
	1	2	3	4	5
Delete a credential	Enter Programming PIN and  OR Present Programming card	Enter  	Enter the PIN or Card ID Number to be deleted and 	To delete another Card credential, go back to step 3 OR press  again to finish	Wait for confirmation: 2 right green blinks.
Change PIN or Card ID Number length	Enter Programming PIN and  OR Present Programming card	Enter   	Enter  	Enter  ,  ,  , OR  for desired PIN length	Press  again to finish Wait for confirmation: 2 right green blinks.
Change relock delay period	Enter Programming PIN and  OR Present Programming card	Enter   	Enter  	Each button press adds to the total delay time Example:  +  adds a 10 second delay	Press  again to finish Wait for confirmation: 2 right green blinks.

Error codes

- ① **All error codes are indicated on the Schlage button by a solid red left LED, and a blinking green right LED. The number of green blinks indicates the error code.**

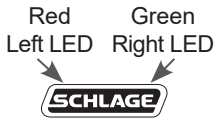
	Number of green blinks	Error code description
		1
	2	Too long programming/user code entered. Programming code must be five (5) digits. User code length cannot exceed six (6) digits.
	3	Memory full, too many codes. Delete some codes.
	4	Programming code cannot be deleted, only changed.
	5	Programming code entries do not match. Programming code not changed.
	6	Invalid command. Invalid function code entered.
	7	Code not found.
	8	Code too short. Programming code length must be five (5) digits. User code minimum length is three (3) digits.
	9	Not a unique code.
	10	Manual programming not allowed.

Test lock operation

If you encounter problems while performing any of the following tests, review the installation guide and correct any problems.

Mechanical test

1. Rotate the inside lever. Operation should be smooth, and the latch should retract.
2. Insert the key into the keyway and rotate the key or the key and lever to open the door. Operation should be smooth, and the latch should retract.

Electronic test

Test the AD-200 in factory default mode

1. For locks with a keypad, press any number key. The lock will beep.
2. Press the Schlage button. The keypad should light blue for a few seconds.
3. For locks with a card reader, present a credential to the reader. The lock will beep and the left side of the Schlage button will blink red one time. When the lock is in factory default mode, no credentials are accepted.
4. In the factory default state, locks with keypads, with or without additional credentials, have a default PIN of **13579** and "#". To test, enter the default PIN. The Schlage button will blink and the lock will unlock.

Test the AD-200 in construction access mode

1. When the master construction credential is presented, the lock will beep and the Schlage button will light green for 20 seconds awaiting the presentation of another credential to be granted Construction User Access.
2. When a valid construction access user credential is presented, the lock will unlock for the re-latch delay period (default three seconds), and the left side of the Schlage button will blink green. When the lock relocks after the relock delay period, the left side of the Schlage button will blink red.
3. If an invalid construction access user credential is presented, the lock will beep and the left side of the Schlage button will blink red one time. For more information, see *Construction access mode* on page 5.

- ① **NOTE: Construction access mode is cancelled when the lock is reset to factory defaults. When construction access mode is cancelled, the master construction credential and all other credentials added using the master construction credential will no longer function.**

Normal lock operation

After credentials have been programmed, present credentials to operate the lock as follows:

Credential type	Action
PIN or Card	Present or enter credential to reader → Green blink → Access granted
Card+Card ID Number	Present credential → Press Card ID Number ¹ → Green blink → Access granted

¹ The default PIN/Card ID length is six digits. The "#" key must be used as an ENTER key for PINs/Card IDs with fewer than six digits. PIN/Card ID length can be manually configured (refer to *Change PIN or Card ID Number length* on page 12).

Wired remote release feature

System and hardware requirements

- Available on AD-200 storeroom function only
- Compatible with AD-200 hardware revision F or higher. See illustration below to locate revision letter on main printed circuit board.
- The AD-200 must be programmed with AD-200 version 2.45.1 firmware or higher.

Switch specifications, wire specifications and routing

- Recommended switch: basic SPST (single-pole single-throw) momentary action switch with normally open contact configuration.
- Wire gauge AWG 24, stranded, twisted pair, shielded (shield may be left unterminated).
- Belden 9841 or equivalent.
- Maximum cable length is 1000 feet (305 meters).
- Route wires from the switch, through the door frame and door to the latch bolt terminals as shown below.

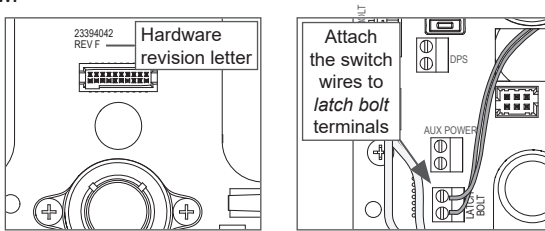

Wired remote release operation

IMPORTANT! The remote release feature will function only when the AD-200 inside cover is completely and properly installed.

Operation with firmware version 2.45.1

- When the remote release button is pressed the lock will unlock for the programmed relock delay period. The Schlage LEDs will flash green once to indicate the lock is unlocked. The beeper will not sound.
- After the relock delay period has expired, the Schlage LEDs will flash red once to indicate the lock is relocked.

Operation with firmware version 2.46.1

- When the remote release button is pressed the lock will unlock for the programmed relock delay period. The green Schlage LEDs and the green inside push button LED will turn on to indicate the lock is unlocked. If the beeper function is turned on, the beeper will sound one time to indicate the lock is unlocked.
- After the relock delay period has expired, the green Schlage LEDs and the green inside push button LED will turn off. If the beeper function is turned on, the beeper will sound two times to indicate the lock is relocked.

Wired remote release button action

- If the remote release button is pressed and held, the release will function only one time, even in the event the button is held longer than the relock delay period.
- If the remote release button is quickly pressed repeatedly, the release will function only one time. Any additional button presses during the relock delay period are ignored.
- Once the lock relocks, the next press of the remote release button will activate a new release cycle.

Reset to factory defaults

All information in the lock will be deleted and reset to factory defaults!

Level 1 factory default reset

- ① **Level 1 factory default reset will delete configurations and settings in the main controller in the lock.**
- ① **Main controller configurations that will reset to factory default include: programming and user codes.**
- ① **Level 1 factory default reset *will not* reset configurations and settings in the reader.**
 1. Remove the top inside cover.
 2. Press and hold the Schlage button until two (2) beeps sound (10 seconds).
 3. Release the Schlage button.
 4. Press and release the inside push button (IPB) three (3) times within 10 seconds. One beep will sound and one red blink will occur with each press.
 5. The Schlage button and IPB will both light green for one second and a one-second beep will be heard. This indicates that the lock has been reset.
- ① **If the IPB is not pressed 3 times within 10 seconds, two beeps with two red blinks indicate timeout.**
- 6. Replace the top inside cover.

Level 2 factory default reset

- ① **Level 2 factory default reset will delete all configurations and settings in the lock and the reader.**
- ① **Reader configurations that will reset to factory default include: keypad format, magstripe reader track, beeper on/off, and contactless card.**
- ① **Days in Use counter and lock type configurations will not reset.**

To complete Level 2 factory default reset, repeat steps 2 through 5 above **within 10 seconds of the confirmation signals of Level 1 factory default reset**. If more than 10 seconds pass after the confirmation signals of Level 1 reset, then Level 1 reset will be repeated.

Batteries

To install or replace batteries

① **Replacement of batteries does not affect any programmed data.**

① **Battery voltage can be checked with the SUS.**

1. Remove the battery cover.
2. Remove the battery bracket. **Do not allow the battery pack to hang from the wires.**
3. Install the new batteries (install only new AA Alkaline batteries).
4. Reinstall the battery pack and battery bracket.
5. Reinstall the battery cover. **Be careful not to pinch the battery wires when installing the battery cover.**

CAUTION! Danger of explosion if battery is incorrectly replaced! Replace only with the same or equivalent type. Dispose of used batteries according to the manufacturer's instructions.

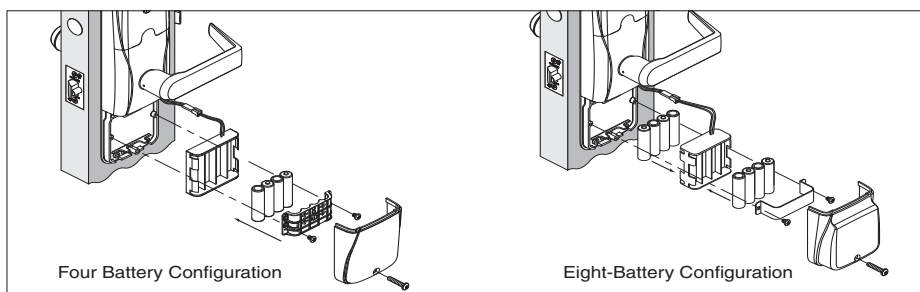

This product has been evaluated for ULC-S319 compliance with AA and coin cell batteries listed below. For installations requiring ULC-S319, these battery models should be used.

AA batteries: Duracell PC1500, MN1500; Energizer E91, EN91, AX91, XR91; RayoVac 815, 815-HE

Coin cell batteries: Energizer CR2025, CR2032; Maxell CR2025, CR2032, Panasonic CR2025, CR2032; RayoVac KECR2025, KECR2032.

Low battery indications

- ① **During low battery condition, the reader's beeper will be temporarily disabled. This condition will revert to normal function when batteries (AA or coin cell) are replaced. (While the beeper is in temporary disabled state, the SUS will indicate beeper is "on" as previously set by the user.)**

Condition	Indicator	Solution
Batteries low	After credential is presented, 9 red blinks of Schlage button. (Left = AA, Right = Coin Cell), then normal indicator.	Replace batteries immediately to avoid battery failure. Lock is intended to operate for 500 cycles in low battery condition.
Battery failure (configured by SUS)	No LED or beeps Valid credentials do not grant access	Replace batteries immediately. Mechanical override key must be used to unlock the lock.

Battery failure modes

- ① **The battery failure mode is set using the SUS. See the SUS User Guide for more information.**

Mode	Description
Fail As-Is (default)	Lock remains in current state until batteries are replaced.
Fail Unlocked ¹	Lock unlocks and remains unlocked until batteries are replaced.
Fail Locked ¹	Lock locks and remains locked until batteries are replaced.

¹ Fail Unlocked and Fail Locked modes are not available if the lock is externally powered.

External power supply

The AD-200 may be connected to external power using a UL294 listed Power Supply for UL installations, and a power supply that complies with CAN/UL-S318 or CAN/ULC-S319 for cUL installations. The power supply must be capable of sourcing at least 250 mA @ 12 or 24 VDC (Schlage PS902, PS904, PS906).

- ① **When powered with external power supply, the lock will always fail "As-Is" if power is lost.**

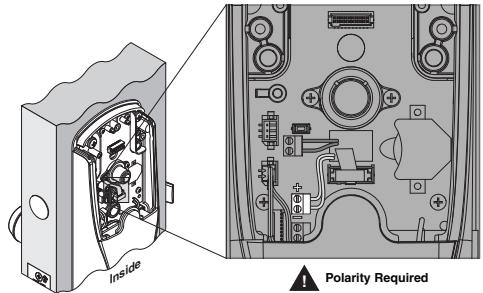

LED Reference

Most LED and beep indicators are configured using the SUS. See the SUS user guide for more information.

Schlage button

Condition	Lights
Access denied	2 red blinks
Access denied, user outside time zone	4 red blinks
Valid PIN entered while lock in freeze mode	12 red blinks indicating lockout
Factory default reset	Solid red while clearing memory, then a one-second solid green when complete.
Waiting for Card ID Number (Card + Card ID Number)	5 left red with right green blinks, then solid right green
Low battery indicator, AA batteries	9 left red blinks
Low battery indicator, coin cell battery	9 right red blinks
Momentary unsecured access	1 green blink, then one red blink on relock
Toggle unsecured	2 green blinks
Toggle secure (relocking)	1 red blink
SUS authentication	Left green solid
USB active with no physical connection	Left green blinking

Optional Inside Push Button (IPB)

Action	Lights
Classroom, Office or Apartment Mode	
Press IPB to lock	1 red blink
Press IPB to unlock	1 green blink
Privacy Mode	
With door closed, press IPB to engage privacy	4 red blinks
With door closed, press IPB to release privacy ¹	4 green blinks

¹ If DPS is used, then opening the door will also release privacy. If mortise deadbolt is used, then retracting the deadbolt will also release privacy.

Troubleshooting

Problem	Possible cause	Solution
<p>The lock beeper does not sound and the keypad does not light when the Schlage button is pressed.</p>	<p>The reader may not be properly seated into the front escutcheon.</p> <p>The reader connector may have bent pins.</p> <p>The through door ribbon cable may not be properly plugged in.</p> <p>The battery or wired power may be improperly connected.</p> <p>The batteries may be inserted with incorrect polarity.</p>	<p>Check that the reader is fully seated into the front escutcheon.</p> <p>Check that there are no bent pins in the reader connector.</p> <p>Check that the through door ribbon cable is plugged in correctly. The red wire should be on the left and not pinched in the door.</p> <p>Check that the battery or wired power is connected correctly.</p> <p>Check that the batteries are inserted in the correct polarity.</p> <p><i>Refer to the installation instructions that came with the AD-200 lock, or this user guide for details on the above mentioned procedures.</i></p>
<p>The reader is not working.</p> <p>The Smart card is not reading.</p> <p>The magnetic swipe card is not reading correctly (no beeps or blinks).</p>	<p>The through hole ribbon cable may be pinched.</p> <p>The Smart card default of the card reader may not be correct for the Smart card.</p> <p>The “Mag Track in Use” default for all Magnetic Card Credential Readers is “Track2”. The magnetic swipe card data may be on Track1 or Track3.</p>	<p>Check that the through hole ribbon cable is not pinched.</p> <p>Change the Smart card format using the SUS. Select AD-200 “Lock Properties”, “Reader” tab, and “Smart cards in use”.</p> <p>Use the SUS to change “Mag Track in Use”. Select AD-200 “Lock Properties”, “Reader” tab, and “MAG Card Track selection”.</p> <p><i>Refer to the installation instructions that came with the AD-200 lock, or the SUS user guide for details on the above mentioned procedures.</i></p>
<p>Wired remote release feature is not working.</p>	<p>The lock may not be compatible with remote release.</p> <p>The hardware or firmware version may not be compatible with remote release.</p> <p>The lock’s inside cover may not be properly or completely installed.</p> <p>The remote release switch may not be functioning correctly.</p>	<p>Wired remote release is available only on the AD-200 storeroom function.</p> <p>Wired remote release is compatible with hardware version F or higher, and with locks programmed with AD-200 version 2.45.1 firmware or higher.</p> <p>Check that the inside cover is completely and properly installed.</p> <p>Check that the switch closes and delivers less than 5 ohms resistance when activated.</p>

FCC/IC Statements

Allegion Agency statements

Compliance Statement

This device complies with Part 15 of the FCC Rules.

Operation is subject to the following two conditions:

1. This device may not cause harmful interference, and
2. This device must accept any interference received, including interference that may cause undesired operation.

Warning

Changes or modifications not expressly approved by the party responsible for compliance could void the user's authority to operate the equipment.

FCC interference statement

This equipment has been tested and found to comply with the limits for a Class B digital device, pursuant to Part 15 of the FCC Rules. These limits are designed to provide reasonable protection against harmful interference in a residential installation. This equipment generates uses and can radiate radio frequency energy and, if not installed and used in accordance with the instructions, may cause harmful interference to radio communications. However, there is no guarantee that interference will not occur in a particular installation. If this equipment does cause harmful interference to radio or television reception, which can be determined by turning the equipment off and on, the user is encouraged to try to correct the interference by one of the following measures:

- Reorient or relocate the receiving antenna.
- Increase the separation between the equipment and receiver.
- Connect the equipment into an outlet on a circuit different from that to which the receiver is connected.

Consult the dealer or an experienced radio/TV technician for help.

Industry Canada statements

This equipment has been tested and found to comply to Industry Canada ICES-003.

CAN ICES-3(B)/NMB-3(B)

Customer Service

1-877-671-7011 www.allegion.com/us



© Allegion 2018
Printed in U.S.A.
P516-129 Rev. 06/18-m