

4. Install channel on door with "A" dimension and 19/32" (15.1) from top of door. Locate "C" dimension sex bolt hole making sure that channel is horizontal and parallel with top edge of door. Drill 1/2" (12.7) dia. sex bolt hole and finish installing holder. Install control knob on channel as shown. Install jamb bracket to angle bracket.

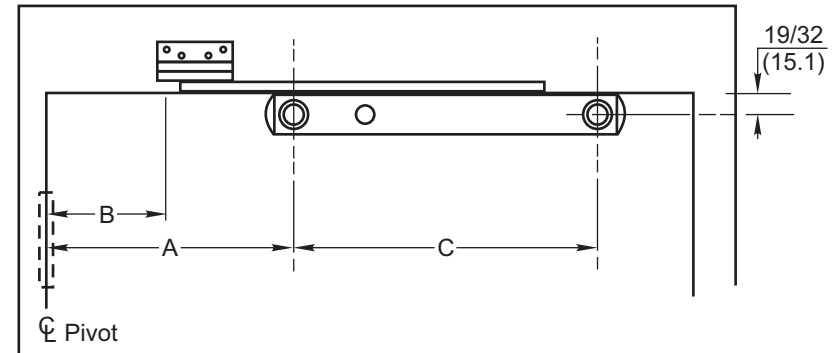

INSTALLATION INSTRUCTIONS

1. Select and determine degree of hold open or dead stop from chart on OH80062B.
2. Locate "A" and "B" dimensions on door and frame.
3. Install angle bracket on front face as shown, using "B" dim. and 1-25/32" (45.2) from jamb to top hole in bracket.

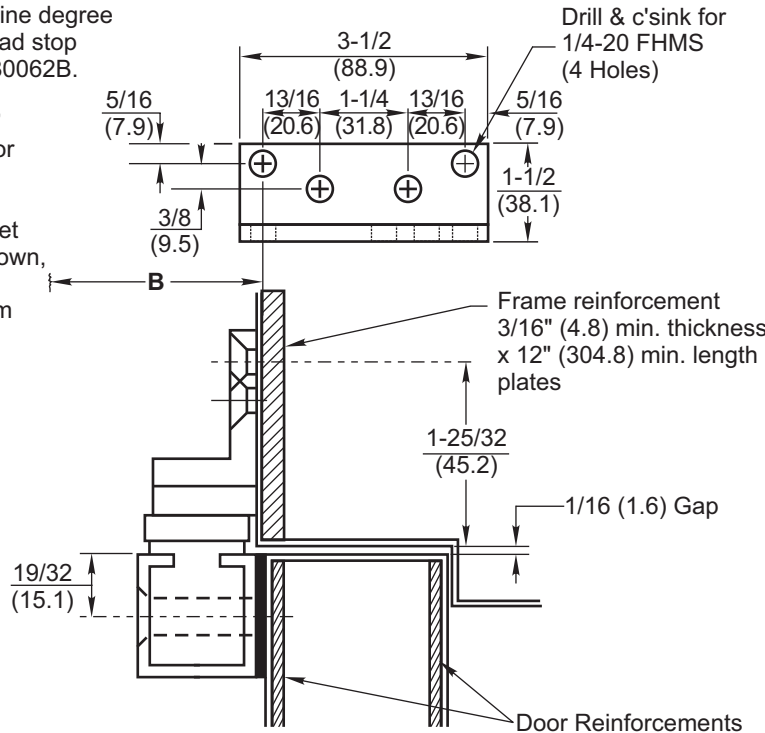

Notes:

- All hollow metal frames should be properly reinforced with 3/16" (4.8) min. thickness x 12"(304.8) min. length reinforcement plates.
- All hollow metal doors should be properly reinforced with 2-1/2" (63.5) wide x 3/16" (4.8) min. thick x full width of door reinforcement plates.
- All drilling and tapping to be done by field men.
- Suggest mounting door stop or holder first and then other hardware to clear.
- Contact factory if interference results with other hardware.
- Left hand shown
- Left hand door use Bracket #5458
- Right hand door use Bracket #5459
- Note hole pattern in jamb bracket.
- All dimensions are given in inches (mm).

Caution:

Note location of swing clear hinge centerline to determine "A" and "B" dimensions.

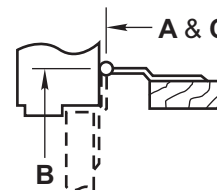

Screw Details	
Jamb	Door
#14-20 x 3/4" FHMS or #14 x 1-1/2" FHWS (4 Places)	5/16-18 x 2" FHMS and 1/2" Dia. Sex Bolt (2 Places)

**No. 9 Series
 Angle Bracket Surface Mounted On Pull Side of Door
 Door Stops and Holders**



No. 9 Series Angle Bracket Surface Mounted on Pull Side of Door

1. See OH80062A for installation instructions.
2. Select proper dimensions noted below.
3. All drilling and tapping to be done by field man.
4. All dimensions given in inches (mm).
 Metric = decimal (numerator divided by denominator) x 25.4.

H.O. = Hold Open
D.S. = Dead Stop

1-3/4 - 2-1/4 (44.5 - 57.2) Butts & 3/4 (19) Offset Pivot	Device Number			Degree Door Opening	85°				90°				95°				100°				105°				110°				
	Friction	H.O.	Stop		H.O.		D.S.		H.O.		D.S.		H.O.		D.S.		H.O.		D.S.		H.O.		D.S.		H.O.		D.S.		
	A	B	A	B	A	B	A	B	A	B	A	B	A	B	A	B	A	B	A	B	A	B	A	B	A	B	A	B	C
9-116	9-126	9-136	25-1/8 - 28-1/2	6-1/8	4-3/4	6-3/4	4-3/4	5-7/8	4-3/8	6-1/2	4-3/8	5-9/16	4-1/16	6-3/16	4-1/16	5-3/8	3-13/16	6	3-13/16	-	-	-	-	-	-	-	-	-	15-15/16
9-216	9-226	9-236	28-9/16 - 33-1/2	7-7/8	5-7/8	8-1/2	5-7/8	7-1/2	5-7/16	8-1/8	5-7/16	7-1/8	5-1/8	7-3/4	5-1/8	6-15/16	4-13/16	7-9/16	4-13/16	6-11/16	4-1/2	7-5/16	4-1/2	6-1/2	4-5/16	7-1/8	4-5/16	17-3/16	
9-316	9-326	9-336	33-9/16 - 38-1/2	11-9/16	7-1/4	12-3/16	7-1/4	11-1/16	6-3/4	11-11/16	6-3/4	10-5/8	6-5/16	11-1/4	6-5/16	10-3/8	5-15/16	11	5-15/16	10	5-5/8	10-5/8	5-5/8	9-3/4	5-3/8	10-3/8	5-3/8	18-11/16	
9-416	9-426	9-436	38-9/16 - 43-1/2	14-7/16	9-1/8	15-1/16	9-1/8	13-7/8	8-1/2	14-1/2	8-1/2	13-3/8	8	14	8	12-15/16	7-9/16	13-9/16	7-9/16	12-3/4	7-3/16	13-3/8	7-3/16	12-3/16	6-7/8	12-13/16	6-7/8	20-13/16	
9-516	9-526	9-536	43-9/16 - 48	18	10-3/8	18-5/8	10-3/8	17-3/8	9-3/4	18	9-3/4	16-13/16	9-1/8	17-7/16	9-1/8	16-3/8	8-5/8	17	8-5/8	15-7/8	8-3/16	16-1/2	8-3/16	15-1/2	7-13/16	16-1/8	7-13/16	22-5/16	

1-3/4 - 2-1/4 (44.5 - 57.2) Center Hung	Device Number			Degree Door Opening	85°				90°				95°				100°				105°				110°			
	Friction	H.O.	Stop		H.O.		D.S.		H.O.		D.S.		H.O.		D.S.		H.O.		D.S.		H.O.		D.S.		H.O.		D.S.	
	A	B	A	B	A	B	A	B	A	B	A	B	A	B	A	B	A	B	A	B	A	B	A	B	A	B	A	B
9-116	9-126	9-136	27-3/8 - 31	6-1/8	5-9/16	6-3/4	5-9/16	5-13/16	5-13/16	6-7/16	5-13/16	5-7/16	4-15/16	6-1/16	4-15/16	5-1/8	4-11/16	5-3/4	4-11/16	4-7/8	4-7/16	5-1/2	4-7/16	4-11/16	4-3/16	5-5/16	4-3/16	15-15/16
9-216	9-226	9-236	31-1/16 - 36	8-1/8	6-1/2	8-3/4	6-1/2	7-5/8	6-1/8	8-1/4	6-1/8	7-1/4	5-3/4	7-7/8	5-3/4	7	5-7/16	7-5/8	5-7/16	6-5/8	5-3/16	7-1/4	5-3/16	6-3/8	4-15/16	7	4-15/16	17-3/16
9-316	9-326	9-336	36-1/16 - 41	11-13/16	8	12-7/16	8	11-1/4	7-1/2	11-7/8	7-1/2	10-13/16	7-1/16	11-7/16	7-1/16	10-7/16	6-11/16	11-1/16	6-11/16	10	6-3/8	10-5/8	6-3/8	9-3/4	6-1/16	10-3/8	6-1/16	18-11/16
9-416	9-426	9-436	41-1/16 - 46	14-3/4	9-3/4	15-3/8	9-3/4	14-1/16	9-3/16	14-11/16	9-3/16	13-9/16	8-11/16	14-3/16	8-11/16	13-1/16	8-3/16	13-11/16	8-3/16	12-5/8	7-13/16	13-1/4	7-13/16	12-1/4	7-1/2	12-7/8	7-1/2	20-13/16
9-516	9-526	9-536	46-1/16 - 50	18-7/16	11-3/16	19-1/16	11-3/16	17-5/8	10-1/2	18-1/4	10-1/2	17-1/8	9-7/8	17-3/4	9-7/8	16-1/2	9-3/8	17-1/8	9-3/8	16	8-7/8	16-5/8	8-7/8	15-5/8	8-1/2	16-1/4	8-1/2	22-5/16

Note: "A" and "B" dimensions measured from centerline of pivot, not edge of door.

**No. 9 Series
 Angle Bracket Surface Mounted On Pull Side of Door
 Door Stops and Holders**



OH80062B 2 of 2 4 08/24