

Mounting details

Hinge (pull) side mounting

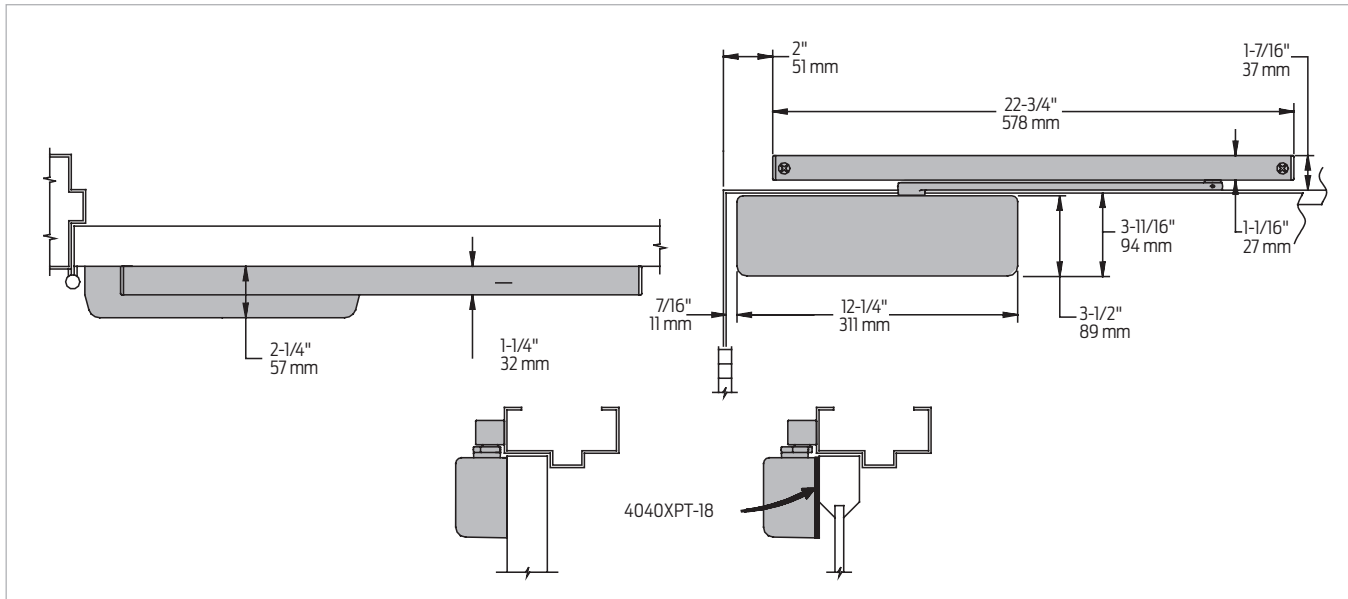

Butt hinges	Should not exceed 5" (127 mm) in width
Auxiliary stop	<ul style="list-style-type: none"> Recommended at hold-open point or where a door cannot swing 120° Optional track bumper assembly assists backcheck in cushioning the opening swing of the door Track bumper is not intended to replace an auxiliary stop
Reveal	Should not exceed 1/8" (3 mm) for standard arm
Top rail	Less than 3 3/4" (95 mm) requires PLATE, 4040XPT-18. Plate requires 1 13/16" (44 mm) minimum
Head frame	Requires 1 1/4" (32 mm) minimum
Clearance	2 1/4" (57 mm) behind door required for 90° installation
Maximum opening	<ul style="list-style-type: none"> Templating allows 120° with standard arm, limited to 110° when optional bumper is installed Variable hold-open angles with infinite options

Note: Consult factory for applications where door must swing 180°.