

Mounting details

Top jamb (push side) mounting

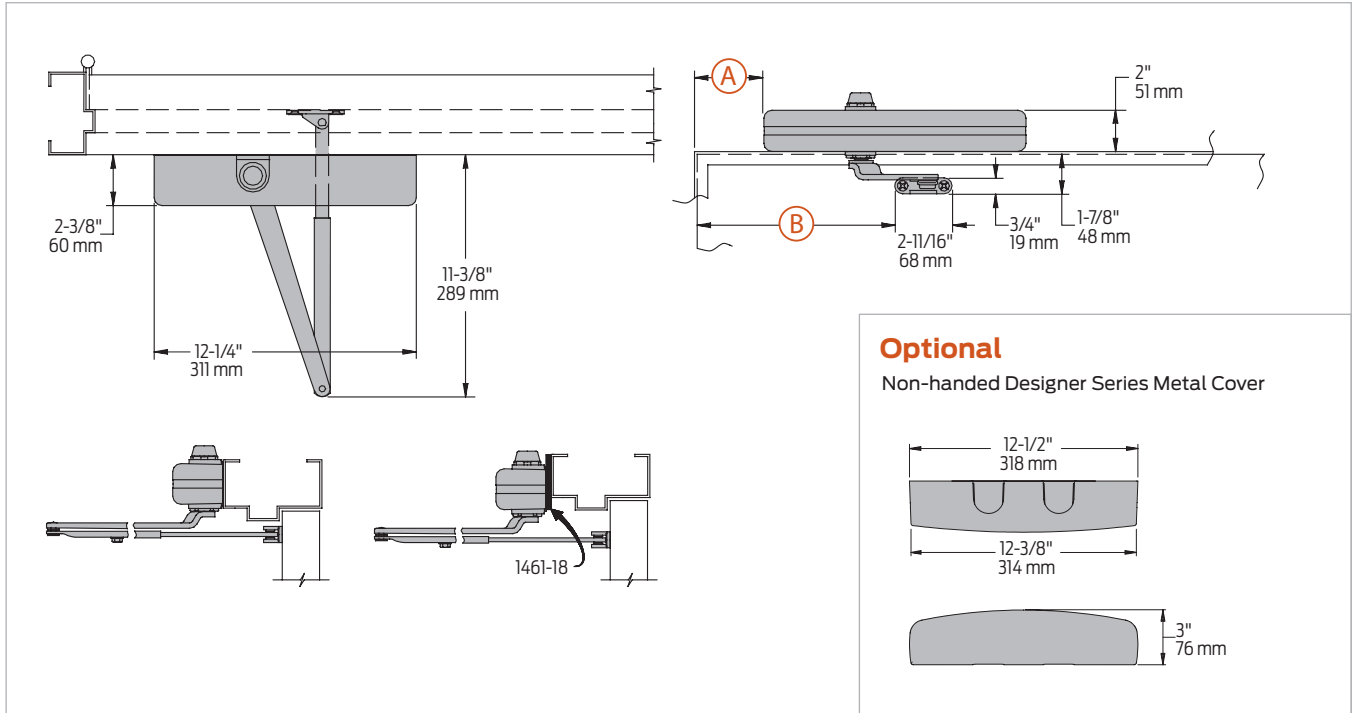

Optional
Non-handed Designer Series Metal Cover

Butt hinges	Should not exceed 5" (127 mm) in width		
Auxiliary stop	Recommended at hold open point or where a door cannot swing 180°		
Reveal	Arm type	Reveal	Max opening
	Regular Arm	4 7/8"	Up to 140°
	Regular Arm	3 1/2"	Up to 180°
	Long Arm	7"	Up to 140°
	Hold Open Arm	2 1/2"	Up to 180°
	Hold Open Long Arm	4 7/8"	Up to 140°
Top rail	Requires 1 7/8" (48 mm) minimum. 2 3/4" (70 mm) minimum with closer on plate, 1460-18		
Head frame	Less than 1 3/4" (44 mm) requires plate, 1460-18. For flush ceiling condition with 2" (51 mm) head frame, use plate, 1460-18		
Delay action	<ul style="list-style-type: none"> ▪ Add suffix "CYLDEL" to selected cylinder ▪ Delays closing: <ul style="list-style-type: none"> - 110° to 75° (using 110° template) - 180° to 95° (using 180° template) ▪ Delay time adjustable up to approximately 1 minute. 		
Maximum opening	110°:	A = 6 3/4" (169 mm) B = 11 1/4" (286 mm)	
	101° to 120°:	A = 3" (76 mm) B = 7 1/2" (191 mm)	

Note: Hold open points up to maximum opening with Hold Open Arm.
* Frame and trim permitting