

Mounting details

Hinge (pull side) mounting

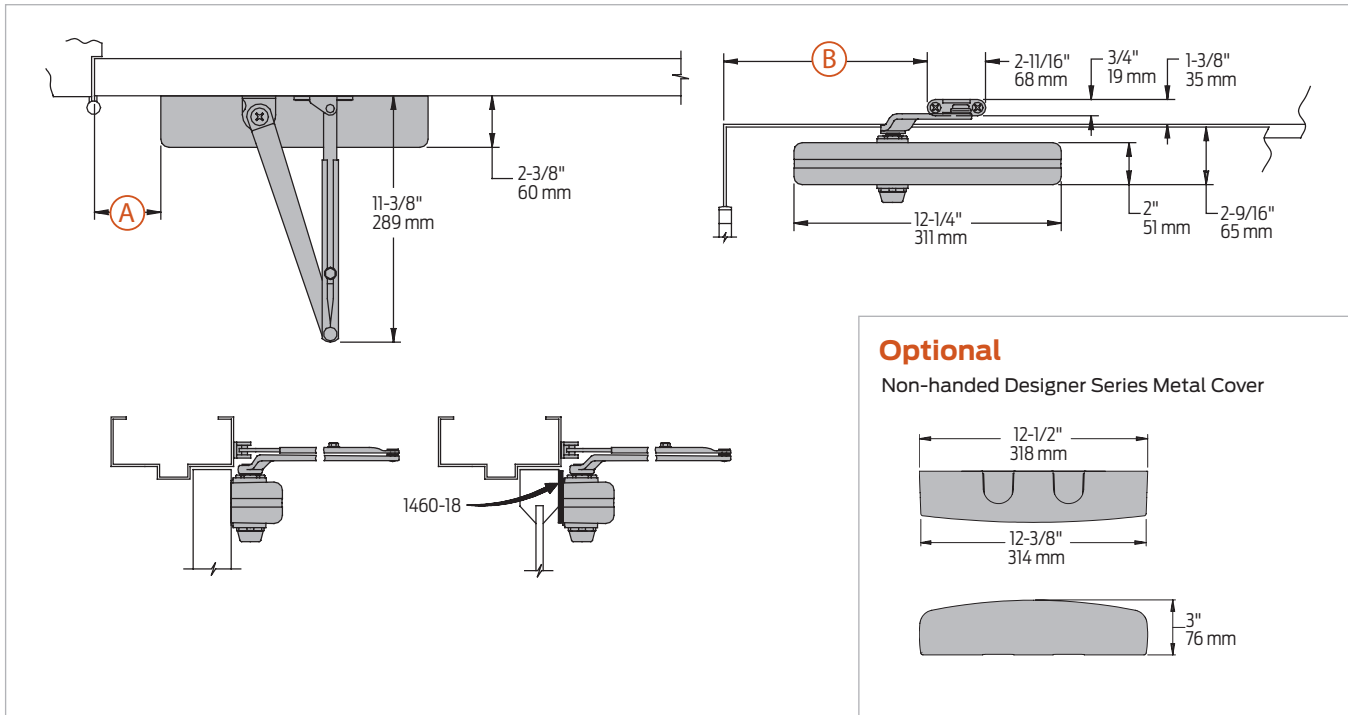

Butt hinges	Should not exceed 5" (127 mm) in width
Auxiliary stop	Recommended at hold open point or where a door cannot swing 180°
Reveal	Should not exceed 3/4" (19 mm) for regular arm or 1/2" (13 mm) for Hold Open Arm
Top rail	<ul style="list-style-type: none"> Less than 2 1/2" (64 mm) requires plate, 1460-18 With Full Plastic Cover, use plate, 1460-18FC. Plate requires 1 1/2" (38 mm) minimum With Designer Series Metal Cover, use plate, 1460-18DS1
Clearance	2 3/8" (60 mm) behind door required for installation
Delay action	<ul style="list-style-type: none"> Add suffix "CYLDEL" to selected cylinder Delays closing from: <ul style="list-style-type: none"> 110° to 65° (using 110° template) 160° to 75° (using 180° template) Delay time adjustable up to approximately 1 minute
Maximum opening	110°: A = 5 7/8" (149 mm) B = 10 7/8" (276 mm)
	or *180° A = 2 7/8" (73 mm) B = 7 7/8" (200 mm)

Note: Hold open points up to maximum opening with Hold Open Arm.
 * Frame and trim permitting