

Mounting details

Top jamb (push side) mounting

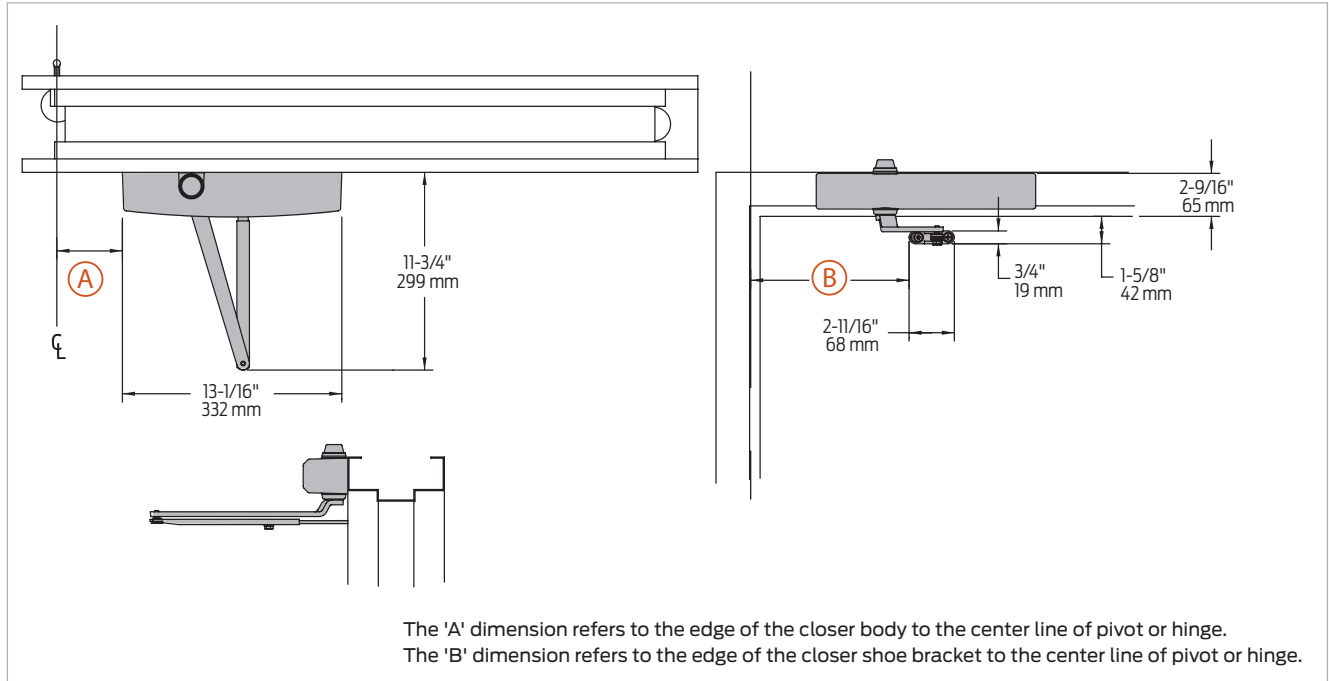

Butt hinges	Should not exceed 5" (127 mm) in width		
Auxiliary stop	Recommended at hold open point or where a door cannot swing 180°		
Reveal	Arm type	Reveal	Max opening
	Regular Arm	5"	Up to 170°
	Regular Arm	3 3/4"	Up to 180°
	Long Arm	8"	Up to 155°
	Hold Open Arm	2 3/4"	Up to 180°
	Hold Open Long Arm	4 7/8"	Up to 140°
Top rail	Requires 2 1/8" (54 mm) minimum. 3 3/8" (86 mm) minimum with closer on plate, 1450-18.		
Head frame	Less than 1 3/4" (44 mm) requires plate, 1450-18. For flush ceiling condition with 1 3/4" (45 mm) head frame, use plate, 1450-18		
Maximum opening	100°:	A=7" (102 mm) B = 12 3/8" (314 mm)	
	101° to 130°:	A = 5 1/2" (140 mm) B = 10 7/8" (276 mm)	
	131° to 180°:	A = 4" (102 mm) B = 9 3/8" (238 mm)	

Note: Hold open points up to maximum opening with Hold Open Arm.
 * Frame and trim permitting