

Mounting details

Hinge (pull side) mounting

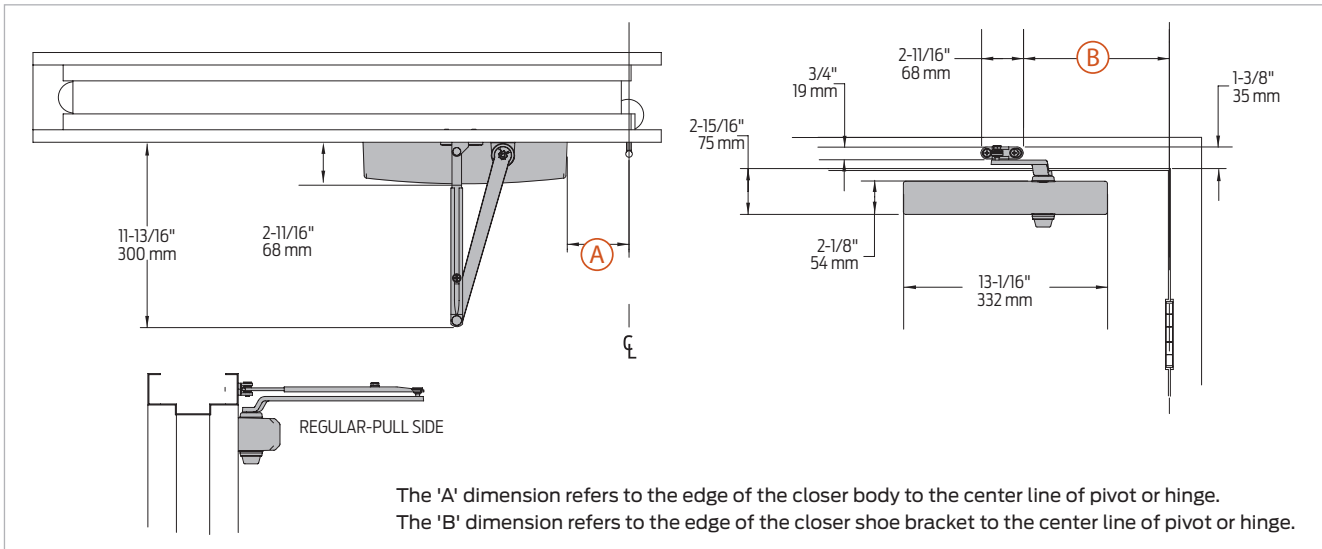

Butt hinges	Should not exceed 5" (127 mm) in width
Auxiliary stop	Recommended at hold open point or where a door cannot swing 180°
Reveal	Should not exceed 3/4" (19 mm) for regular arm or 1/2" (13 mm) for Hold Open Arm
Top rail	<ul style="list-style-type: none"> Less than 2 1/2" (64 mm) requires plate, 1450-18 With full cover, use plate, 1450-18FC. Plate requires 1 1/2" (38 mm) minimum
Clearance	2 3/8" (60 mm) behind door required for installation
Maximum opening	100°: A = 7" (102 mm) B = 12 3/8" (314 mm)
	101° to 130°: A = 5 1/2" (140 mm) B = 10 7/8" (276 mm)
	131° to 180°: A = 4" (102 mm) B = 9 3/8" (238 mm)

Note: Hold open points up to maximum opening with Hold Open Arm.
* Frame and trim permitting