

Mounting details

Parallel arm (push side) mounting

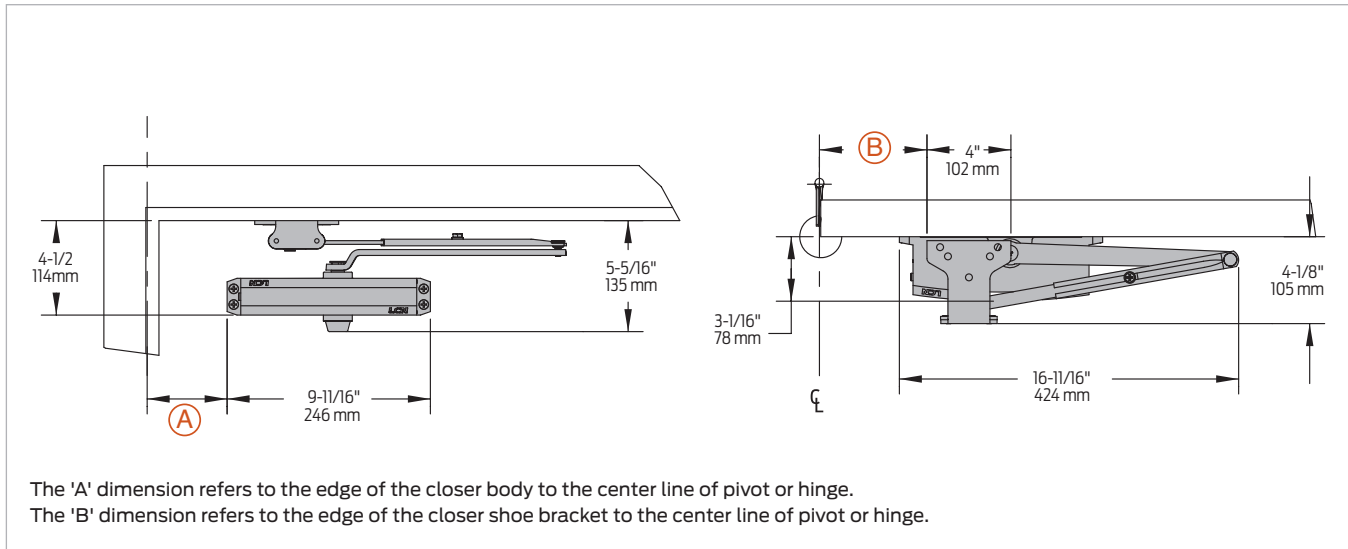

Butt hinges	Should not exceed 5" (127 mm) in width
Auxiliary stop	Recommended at hold open point, where a door cannot swing 180°, or where Cush-n-Stop Arm is not used
Top rail	Less than 4 1/2" (114 mm) measured from the stop requires plate, 1250-18PA
Clearance	1250-62PA shoe projects 4 1/8" (105 mm) from door face
Stop width	Minimum 1" (25 mm)
Blade stop	Clearance, requires 1/2" (13 mm) blade stop spacer, 1250-61
Auxiliary shoe	1250-62A allows installation of regular arm with overhead holder/stop
Maximum opening	Regular or Hold Open Arm can be templated to 100°: A = 7 5/16" (186 mm) B = 8 5/8" (219 mm) or 101° to 130°: A = 5 13/16" (148 mm) B = 7 1/8" (181 mm) or *131° to 180°: A = 3 13/16" (97 mm) B = 5 1/8" (130 mm)

Note: Hold open points up to maximum opening with Hold Open Arm. 1250 Parallel arm closer includes 1250-201 fifth hole spacer to support PA shoe.
* Frame and trim permitting.