

**INSTALLATION INSTRUCTIONS
2930 ELECTRIC STRIKE**



2930 CYL for cylindrical locksets and Hager mortise exit device with 1/2" to 3/4" latch.



2930 MOR For mortise locksets with up to a 3/4" latch



2930 MDB for mortise locksets with latch and deadbolt

Hager 2930 heavy duty electric strikes are designed for use with cylindrical and mortise locksets and mortise exit devices. Several faceplate configurations eliminate the need for centerline relocation, making them perfect for new or retrofit construction.

OPTIONAL MONITORING OUTPUTS:

DSM (Door Secure Monitor)

Signals keeper is closed and deadlocked and/or unlocked.

LBM (Latch Bolt Monitor)

Signals latch is extended into strike and/or retracted.

DBM (Deadbolt Monitor)

Signals deadbolt is extended into strike and /or retracted.

Strike Input - Minimum Wire Gauge Requirements					
Voltage	100 ft	150 ft	200 ft	250 ft	300 ft
12VDC	18 Ga	16 Ga	14 Ga	14 Ga	---
24VDC	18 Ga	18 Ga	18 Ga	16 Ga	16 Ga



Warnock Hersey Tested according to:
UL 10C, 3 Hr Fire Rated (Fail-Secure only).
UL Tested according to:
UL 1034 Burglary-Resistant

Monitoring outputs: Minimum 22 Gage wire recommended

Use Voltage Regulator for all Fail Safe applications.

OPERATION:





Fail-Secure (Power-to-Unlock): Unlocked when energized.
Locked when de-energized and during power failure.

Application: For non fire rated and fire rated doors (exception, may not be used on stairwell doors). May not be maintained in the unlocked (energized) state when used with fire rated doors.

Fail-Safe (Power-to-Lock): Locked when energized.
Unlocked when de-energized and during power failure.

Application: Non-fire rated doors only.

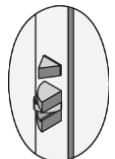
CAUTION: Fail-safe is **not** permitted with the UL Fire Door Accessory label.

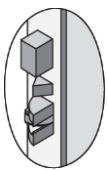
Model	Lockset	Application	Compatible Locks	Operation
2930 CYL 		<ul style="list-style-type: none"> • Bored (Cylindrical) locks. • Hager Mortise Exit Devices. • No relocation of the centerline. 	<ul style="list-style-type: none"> • All cylindrical locksets with .5" or .625" latchbolts • Adams Rite 4720 ANSI and compatible narrow stile locks. 	<p>After releasing the latchbolt, the keeper returns to the locked position.</p>
2930 MOR 		<ul style="list-style-type: none"> • Mortise locksets with or without a deadlatch located above the latchbolt. • For new and retrofit installations. • No relocation of the centerline. 	<ul style="list-style-type: none"> • SDC • Baldwin • Hager • Schlage 	<p>After releasing the latchbolt, the keeper returns to the locked position.</p>
2930 MDB 		<ul style="list-style-type: none"> • Mortise locksets with a deadbolt and a deadlatch located above the latchbolt. • For new and retrofit installation • Deadbolt will not release. 	<ul style="list-style-type: none"> • SDC • Schlage • Hager 	<p>When the deadbolt is projected manually, the strike will not release. When the deadbolt is retracted, access is accomplished by electrically releasing the keeper.</p>

INSTALLATION

1. Verify lock compatibility, refer to **page 2** and **Fig. 6, page 4**.
2. For proper frame preparation, refer to template drawings, **Fig. 4 & 5, page 4**.
2. Factory supplied in Failsecure mode. For Failsafe mode refer to **Fig. 2, page 3**
3. Determine minimum wire gauge required. See wire gauge chart on page 1.
4. **CAUTION!** Before connecting power wires check for proper operating voltage at opening with a volt meter. Voltage must be within +/- 10% of strike operating voltage for proper operation.
5. Configure strike for 12 or 24VDC operation. Refer to pigtail power connector wiring in **Fig. 1, Page 3**. Connect wires to power source.
6. To install the strike into the frame opening:
 - A) Position the wiring either down or up or toward the back of the hollow metal frame. Make sure wires are completely clear of strike, so they are not pinched when mounting strike in the frame.
 - B) Insert mounting screws through the faceplate and secure into mounting tabs.
7. After installation check horizontal alignment. There should be 1/32" allowable movement when the door is pulled toward the keeper.
8. ALIGNMENT ADJUSTMENT: Loosen mounting screws, shift strike body behind faceplate horizontally as shown in **Fig. 3A, page 3**, then tighten mounting screws.
9. For excessive horizontal alignment issues, remove shim filer bar from the keeper as shown in **Fig. 3B, page 3**
10. The Electric Door Strike MUST be installed in such a way and in such a location so as not to impair the operation of an emergency exit or panic hardware mounted on the door.

FIG. 1

WIRE DIAGRAM - 2930 SERIES ELECTRIC STRIKE

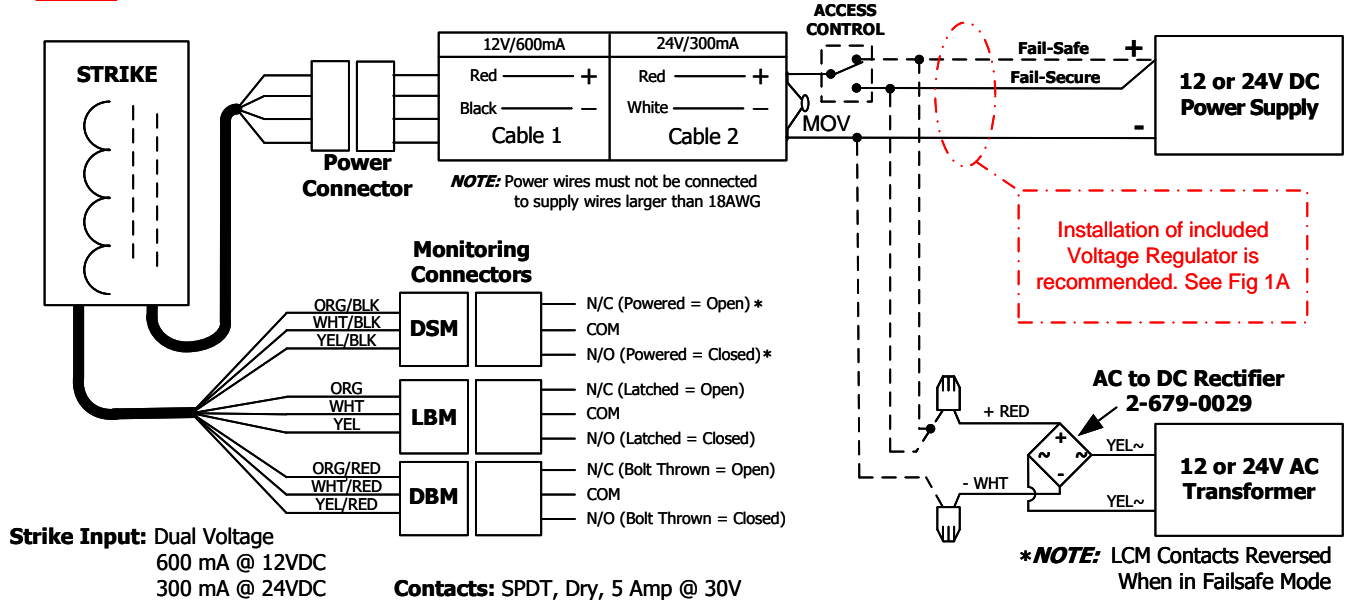

HIGH SECURITY DOOR SECURE MONITORING: DSM & LBM Required

DSM & LBM wired in series indicates door is closed, latched and strike is deadlocked or door is open or unlocked

FAIL SECURE MODE – Door Secure or Unlocked Status

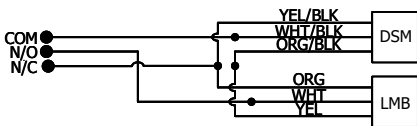

FAIL SAFE MODE – Door Secure or Unlocked Status

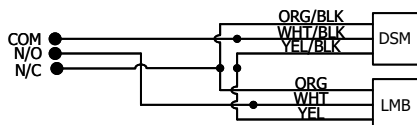

Missing Jumper – 12VDC or 24VDC Connections without Jumper

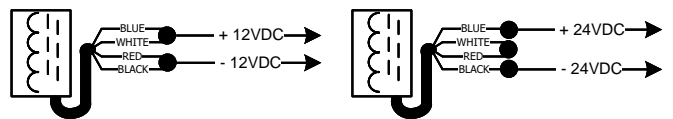

Fig 1A –Voltage Regulator Installation

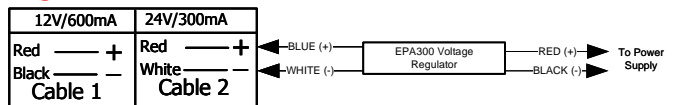

FIG. 2 FIELD REVERSIBLE FAILSAFE / FAILSECURE

Failsecure Mode: Factory supplied, Failsecure
Failsafe Mode: Remove cover, loosen 2 flathead screws, push solenoid toward end of strike as shown below, and retighten screws.

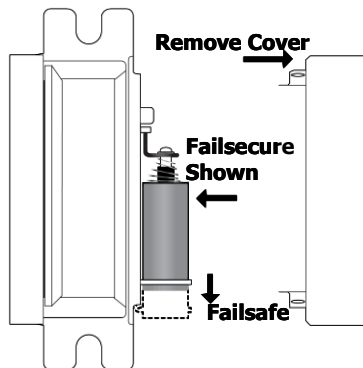

FIG. 3 HORIZONTAL ALIGNMENT ADJUSTMENT

3A-Nominal Alignment: Loosen mounting screws. Shift strike body behind the faceplate horizontally. Tighten mounting screws.
3B-Excessive Alignment Issues: Remove shim filler bar from keeper.

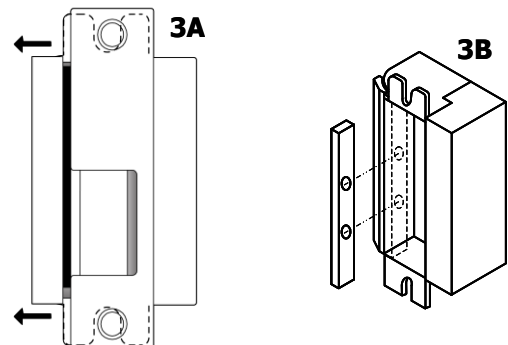

FIG. 4 FRAME PREPARATION – 2930 Electric Strike

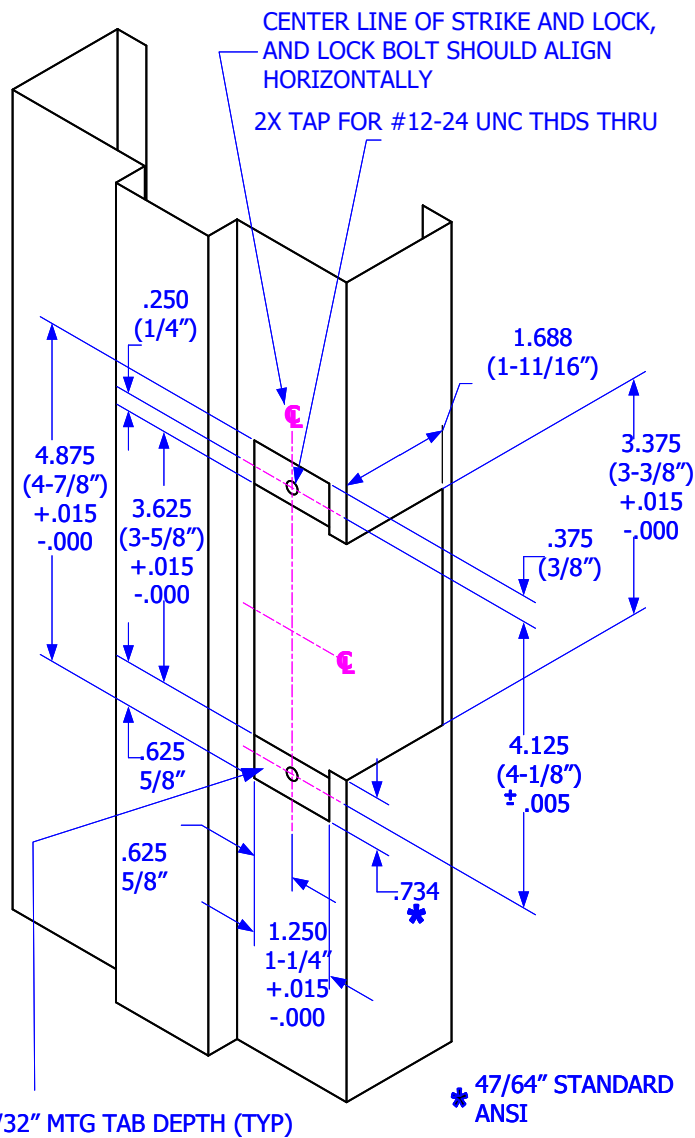

FIG. 5 STRIKE DIMENSIONS

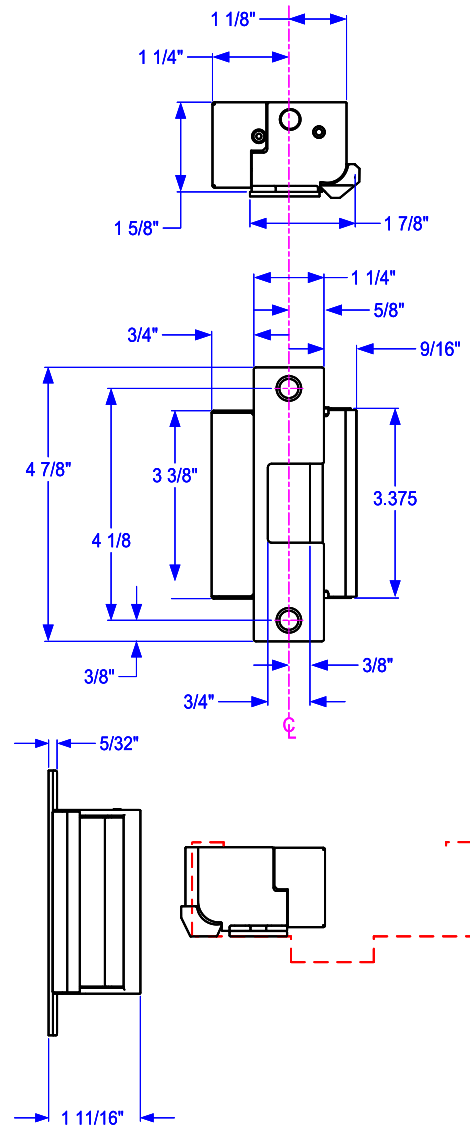

FIG. 6 FACE PLATES – All faceplates are interchangeable for application requirements

2930 CYL

2930 MOR

2930 MDB

